



---

---

AIM & THURLBY THANDAR INSTRUMENTS

TGA12100 Series

---

---

100MHz Arbitrary Waveform Generators

INSTRUCTION MANUAL

Aim-TTi

---

# Table of Contents

Introduction	3
Specifications	5
Safety	13
Installation	14
Connections	16
Front Panel Connections	16
Rear Panel Connections	17
General	19
Initial Operation	19
Principles of Editing	20
Principles of Operation	21
Standard Waveform Operation	23
Setting Generator Parameters	23
Warnings and Error Messages	25
SYNC Output	26
Sweep Operation	28
General	28
Setting Sweep Parameters	28
Triggered Burst and Gate	32
General	32
Triggered Burst	33
Gated Mode	35
Sync Out in Triggered Burst and Gated Mode	36
Tone Mode	37
Arbitrary Waveform Generation	39
Introduction	39
Selecting and Outputting Arbitrary Waveforms	40
Creating New Waveforms	40
Modifying Arbitrary Waveforms	41
Arbitrary Waveform Sequence	47
Frequency and Amplitude Control with Arbitrary Waveforms	48
Sync Out Settings with Arbitrary Waveforms	49
Waveform Hold in Arbitrary Mode	50
Output Filter Setting	50
Pulse and Pulse-trains	51
Pulse Set-up	51
Pulse-train Setup	53

---

Waveform Hold in Pulse and Pulse-Train Modes	56
Modulation	57
Introduction	57
External Modulation	57
Internal Modulation	58
Sum	59
Inter-Channel Synchronisation	61
Synchronising Two Generators	64
Memory Card and Other System Operations from the Utility Menu	66
Memory Card – General Information	66
System Operations from the Utility Menu	68
Calibration	72
Equipment Required	72
Calibration Procedure	72
Calibration Routine	73
Remote Calibration	76
Remote Operation	77
Power on Settings	84
Remote Commands	85
Channel Selection	86
Frequency and Period	86
Amplitude and DC Offset	86
Waveform Selection	87
Arbitrary Waveform Create and Delete	87
Arbitrary Waveform Editing	88
Waveform Sequence Control	90
Mode Commands	90
Input/Output control	90
Modulation Commands	91
Synchronising Commands	91
Status Commands	91
Miscellaneous Commands	92
Remote Command Summary	93
Maintenance	97
Appendix 1. Warning and Error Messages	98
Appendix 2. SYNC OUT Automatic Settings	102
Appendix 3. Factory System Defaults	103
Appendix 4. Waveform Manager Plus Arbitrary Waveform Creation and Management Software	104
Block Diagrams	105

---

This range of synthesised programmable arbitrary waveform generators has the following features:

- 1, 2 or 4 independent arb channels
- Additional DC to 50MHz fixed amplitude sine and squarewave outputs on 2- and 4-channel instruments
- Up to 100MHz sampling frequency
- Sinewaves up to 40MHz, squarewaves up to 50MHz
- Output level 2.5mV to 10Vp-p into 50Ω with 12 bit vertical resolution
- 1M points horizontal resolution per channel
- Compact Flash card for non-volatile waveform memory
- Waveform linking, looping and sequencing
- Interchannel triggering, summing, modulation and phase control
- GPIB, RS232 and USB interfaces

The instrument uses a combination of direct digital synthesis and variable clock techniques to provide high performance and extensive facilities in a compact instrument. It can generate a wide variety of waveforms between 0.1mHz and 50MHz with high resolution and accuracy.

Arbitrary waveforms may be defined with 12 bit vertical resolution and from 8 to 1048576 horizontal points. In addition a number of standard waveforms are available including sine, square, triangle, ramp and pulse.

Arbitrary waveforms may be replayed at a user specified waveform frequency or period, or the sample rate may be defined in terms of period or frequency. Alternatively, an external Arb clock may be used at frequencies up to 50MHz.

Extensive waveform editing features between defined start and end points are incorporated, including waveform insert, point edit, line draw, amplitude adjust and invert. More comprehensive features are available using the arbitrary waveform creation software supplied. This is a powerful Windows-based design tool that enables the user to create waveforms from mathematical expressions, from combinations of other waveforms, freehand, or using a combination of all three techniques. Waveforms created in this way can be downloaded via the RS232, GPIB or USB interfaces or transferred directly to the generator on a removable memory card written to by the PC using the USB-connected card reader/writer provided.

Up to 500 different waveforms may be stored with the length and name specified by the user; the total size of all the waveforms stored is limited only by the size of the memory card. Waveforms may be linked together to form a sequence of up to 1024 steps. Each waveform may have a user defined repeat count from 1 to 32768.

All waveforms can be swept over their full frequency range at a rate variable between 1 millisecond and 15 minutes. Sweep can be linear or logarithmic, single or continuous. Single sweeps can be triggered from the front panel, the trigger input, or the digital interfaces. A sweep marker is provided.

Amplitude Modulation is available for all waveforms and is controlled from the previous channel or from an external generator via the MODULATION input socket.

Signal Summing is available for all waveforms and is controlled from the previous channel or from an external generator via the SUM input socket.

---

All waveforms are available as a Triggered Burst whereby each active edge of the trigger signal will produce one burst of the carrier. The number of cycles in the burst can be set between 1 and 1048575. The Gated mode turns the output signal On when the gating signal is true and Off when it is false. Both Triggered and Gated modes can be operated from the previous or next channel, from the internal Trigger Generator (0.005Hz to 100kHz), from an external source (dc to 1MHz) or by a key press or remote command.

Any number of channels can be synchronised with user defined phase angle between channels. This can be used to generate multi-phase waveforms or synchronised waveforms of different frequencies.

The signals from the REF IN/OUT socket and the SYNC OUT socket can be used to synchronise two instruments where more than 4 channels are required.

The generator parameters are clearly displayed on a backlit LCD with 4 rows of 20 characters. Soft-keys and sub menus are used to guide the user through even the most complex functions.

All parameters can be entered directly from the numeric keypad. Alternatively most parameters can be incremented or decremented using the rotary control. This system combines quick and easy numeric data entry with quasi-analogue adjustment when required.

The generator has RS232, GPIB and USB interfaces as standard which can be used for remote control of all of the instrument functions or for the down-loading of arbitrary waveforms. As well as operating in conventional RS232 mode the serial interface can also be used in addressable mode whereby up to 32 instruments can be linked to a single PC serial port.

Specifications apply at 18–28°C after 30 minutes warm-up, at maximum output into 50Ω

## WAVEFORMS

### Standard Waveforms

Sine, square, triangle, DC, positive ramp, negative ramp,  $\sin(x)/x$ , pulse, pulse train, cosine, haversine and havercosine.

### Sine, Cosine, Haversine, Havercosine

Range:	0.1mHz to 40MHz
Resolution:	0.1mHz or 10 digits
Accuracy:	10 ppm for 1 year
Temperature Stability:	Typically <1 ppm/°C.
Output Level:	2.5mV to 10Vp-p into 50Ω
Harmonic Distortion:	<0.15% THD to 100kHz; <-60dBc to 20kHz <-50dBc to 1MHz, <-40dBc to 10MHz <-30dBc to 40MHz
Non-harmonic Spuri:	<-60dBc to 1MHz, <-60dBc + 6dB/octave 1MHz to 40MHz

### Square

Range:	1mHz to 50MHz
Resolution:	1mHz or 8 digits
Accuracy:	10ppm for 1 year
Output Level:	2.5mV to 10Vp-p into 50Ω
Rise and Fall Times:	<8ns

### Triangle

Range:	0.1mHz to 500kHz
Resolution:	0.1mHz or 10 digits
Accuracy:	10 ppm for 1 year
Output Level:	2.5mV to 10Vp-p into 50Ω
Linearity Error:	<0.1% to 30 kHz

### Ramps and Sin(x)/x

Range:	0.1mHz to 500kHz
Resolution:	0.1mHz (10 digits)
Accuracy:	10 ppm for 1 year
Output Level:	2.5mV to 10Vp-p into 50Ω
Linearity Error:	<0.1% to 30 kHz

---

## Pulse and Pulse Train

Output Level:	2.5mV to 10Vp-p into 50Ω
Rise and Fall Times:	<8ns
Period:	
Range:	40ns to 100s
Resolution:	8-digit
Accuracy:	10ppm for 1 year
Delay:	
Range:	-99.99s to + 99.99s
Resolution:	0.001% of period or 10ns, whichever is greater (8 digits)
Width:	
Range:	10ns to 99.99s
Resolution:	0.001% of period or 10ns, whichever is greater (8 digits)

Note that the pulse width and absolute value of the delay may not exceed the pulse period at any time.

Pulse trains of up to 10 pulses may be specified, each pulse having independently defined width, delay and level. The baseline voltage is separately defined and the sequence repetition rate is set by the pulse train period.

## Arbitrary

Up to 500 user defined waveforms may be stored on the removable memory card. Waveforms can be defined by front panel editing controls, by downloading of waveform data via RS232, GPIB or USB, or by writing directly to the removable memory card using the USB card reader/writer connected to a PC.

Waveform Memory Size:	1M points per channel – minimum waveform size is 8 points
Vertical Resolution:	12 bits
Sample Clock Range:	100mHz to 100MHz
Resolution:	8 digits
Accuracy:	10ppm for 1 year

## Sequence

Up to 1024 waveforms may be linked. Each waveform can have a loop count of up to 32,768. A sequence of waveforms can be looped up to 1,048,575 times or run continuously.

## Output Filter

Selectable between 40MHz Elliptic, 20MHz Bessel or none.

## Noise

Digital noise generated by a 35-bit linear feedback register clocked at 100MHz. User's external filter defines bandwidth and response.

---

## OPERATING MODES

### Triggered Burst

Each active edge of the trigger signal will produce one burst of the waveform.

Carrier Waveforms:	All standard and arbitrary
Maximum Carrier Frequency:	The smaller of 2.5MHz or the maximum for the selected waveform. 100Msamples/s for ARB or Sequence.
Number of Cycles:	1 to 1,048,575
Trigger Repetition Rate:	0.005Hz to 100kHz internal dc to 1MHz external.
Trigger Signal Source:	Internal from keyboard, previous channel, next channel or trigger generator. External from TRIG IN or remote interface.
Trigger Start/Stop Phase:	$\pm 360^\circ$ settable with $0.1^\circ$ resolution, subject to waveform frequency and type.

### Gated

Waveform will run while the Gate signal is true and stop while false.

Carrier Waveforms:	All standard and arbitrary.
Maximum Carrier Frequency:	The smaller of 2.5MHz or the maximum for the selected waveform. 100Msamples/s for ARB or Sequence.
Trigger Repetition Rate:	0.005Hz to 100kHz internal dc to 1MHz external.
Gate Signal Source:	Internal from keyboard, previous channel, next channel or trigger generator. External from TRIG IN or remote interface.
Gate Start/Stop Phase:	$\pm 360^\circ$ settable with $0.1^\circ$ resolution, subject to waveform frequency and type.

### Sweep

Frequency sweep capability is provided for both standard and arbitrary waveforms. Arbitrary waveforms are expanded or condensed to exactly 4096 points and DDS techniques are used to perform the sweep.

Carrier Waveforms:	All standard and arbitrary except pulse, pulse train and sequence.
Sweep Mode:	Linear or logarithmic, triggered or continuous.
Sweep Direction:	Up, down, up/down or down/up.
Sweep Range:	From 1mHz to 40MHz in one range. Phase continuous. Independent setting of the start and stop frequency.
Sweep Time:	1ms to 999s (3 digit resolution).
Marker:	Variable during sweep.
Sweep Trigger Source:	The sweep may be free run or triggered from the following sources: Manually from keyboard. Externally from TRIG IN input or remote interface.
Sweep Hold:	Sweep can be held and restarted by the HOLD key.
Multi channel sweep:	Any number of channels may be swept simultaneously with independent sweep parameters for each channel. Amplitude, Offset and Waveform can be set independently for each channel.



---

## Tone Switching

Capability provided for both standard and arbitrary waveforms. Arbitrary waveforms are expanded or condensed to exactly 4096 points and DDS techniques are used to allow instantaneous frequency switching.

Carrier Waveforms:	All waveforms except pulse, pulse train and sequence.
Frequency List:	Up to 16 frequencies from 1mHz to 40MHz.
Trigger Repetition Rate:	0.005Hz to 100kHz internal dc to 1MHz external. Usable repetition rate and waveform frequency depend on the tone switching mode.
Source:	Internal from keyboard, previous channel, next channel or trigger generator. External from TRIG IN or remote interface.
Tone Switching Modes:	
Gated:	The tone is output while the trigger signal is true and stopped, at the end of the current waveform cycle, while the trigger signal is false. The next tone is output when the trigger signal is true again.
Triggered:	The tone is output when the trigger signal goes true and the next tone is output, at the end of the current waveform cycle, when the trigger signal goes true again.
FSK:	The tone is output when the trigger signal goes true and the next tone is output, immediately, when the trigger signal goes true again.

Using 2 channels with their outputs summed together it is possible to generate DTMF test signals.

## Trigger Generator

Internal source 0.005 Hz to 100kHz square wave adjustable in 10us steps. 3 digit resolution. Available for external use from any SYNC OUT socket.

## OUTPUTS

### Main Output - One for each channel

Output Impedance:	50 $\Omega$
Amplitude:	5mV to 20Vp-p open circuit (2.5mV to 10Vp-p into 50 $\Omega$ ). Amplitude can be specified open circuit (hi Z) or into an assumed load of 50 $\Omega$ or 600 $\Omega$ in Vpk-pk, Vrms or dBm.
Amplitude Accuracy:	2% $\pm$ 1mV at 1kHz into 50 $\Omega$ .
Amplitude Flatness:	$\pm$ 0.2dB to 1MHz; $\pm$ 0.4dB to 40MHz
DC Offset Range:	$\pm$ 10V. DC offset plus signal peak limited to $\pm$ 10V from 50 $\Omega$ .
DC Offset Accuracy:	Typically 3% $\pm$ 10mV, unattenuated.
Resolution:	3 digits or 1mV for both Amplitude and DC Offset.

---

## Sync Out - One for each channel

Multifunction output user definable or automatically selected to be any of the following:

Waveform Sync: (all waveforms)	A square wave with 50% duty cycle at the main waveform frequency, or a pulse coincident with the first few points of an arbitrary waveform.
Position Markers: (Arbitrary only)	Any point(s) on the waveform may have associated marker bit(s) set high or low.
Burst Done:	Produces a pulse coincident with the last cycle of a burst.
Sequence Sync:	Produces a pulse coincident with the end of a waveform sequence.
Trigger:	Selects the current trigger signal. Useful for synchronizing burst or gated signals.
Sweep Sync:	Outputs a trigger signal at the start of sweep to synchronize an oscilloscope or recorder. Can additionally output a sweep marker.
Phase Lock Out:	Used to synchronise two generators. Produces a positive edge at the 0° phase point.
Output Signal Level:	Logic level of <0.8V to >3V for all outputs except Sweep Sync. Sweep Sync is a 3-level waveform, logic level as above at start of sweep, with narrow 1V pulses at each marker point.

## Auxiliary Sine Out

Frequency Range:	DC to 50MHz, set by System Clock
Output Signal Level:	1V <sub>p-p</sub> into 50Ω

## System Clock

Frequency Range:	DC to 50MHz, 0.1Hz resolution
------------------	-------------------------------

## INPUTS

### Trig In

Frequency Range:	DC – 1MHz.
Signal Range:	Threshold level adjustable ±5V; maximum input ±10V.
Minimum Pulse Width:	50ns, for Trigger and Gate modes; 50us for Sweep mode.
Polarity:	Selectable as high/rising edge or low/falling edge.
Input Impedance:	10kΩ

### Modulation In

Frequency Range:	DC – 100kHz.
Signal Range:	VCA: Approximately 1V pk-pk for 100% level change at maximum output; maximum input ±10V. SCM: Approximately ± 1Vpk for maximum output.
Input Impedance:	Typically 1 kΩ.

### Sum In

Frequency Range:	DC – 30 MHz (25MHz on 2- and 4-channel instruments).
Signal Range:	Approximately 2 Vpk-pk input for 20Vpk-pk output; maximum input ±10V.
Input Impedance:	Typically 1kΩ.

---

## Hold

Holds an arbitrary waveform at its current position. A TTL low level or switch closure causes the waveform to stop at the current position and wait until a TTL high level or switch opening which allows the waveform to continue. The front panel MAN HOLD key or remote command may also be used to control the Hold function. The Hold input may be enabled independently for each channel.

Input Impedance: 10k $\Omega$

Maximum Input Voltage:  $\pm 10V$

## Ref Clock In/Out

Set to Input: Input for an external 10MHz reference clock. TTL/CMOS threshold level.

Set to Output: Buffered version of the internal 10MHz clock. Output levels nominally 1V and 4V from 50 $\Omega$ .

Set to Phase Lock: Used together with SYNC OUT on a master and TRIG IN on a slave to synchronise (phase lock) two separate generators.

Maximum Input Voltage: +5V, -1V.

## Arb Clock In/Out

Set to Input: Input for External Arb Clock. TTL/CMOS threshold level,

Set to Output: Outputs System Clock, logic levels <0.8V and >3V.

Frequency Range: DC to 50MHz

Maximum Input Voltage: +5V, -1V.

## INTER-CHANNEL OPERATION

### Inter-channel Modulation:

The waveform from any channel may be used to Amplitude Modulate (AM) or Suppressed Carrier Modulate (SCM) the next channel. Alternatively any number of channels may be Modulated (AM or SCM) with the signal at the MODULATION input socket.

Carrier frequency: Entire range for selected waveform.

Carrier waveforms: All standard and arbitrary waveforms.

Modulation Types:

AM: Double sideband with carrier.

SCM: Double sideband suppressed carrier.

Modulation source:

Internal from the previous channel.

External from Modulation input socket.

The external modulation signal may be applied to any number of channels simultaneously.

Frequency Range: DC to >100 kHz.

Internal AM:

Depth: 0% to 105%

Resolution: 1%.

Carrier Suppression (SCM): > -40dB.

External Modulation Signal Range:

VCA: Approximately 1V pk-pk for 100% level change at maximum output.

SCM: Approximately  $\pm 1V$ pk for maximum output.

---

## Inter-channel Analog Summing:

Waveform Summing sums the waveform from any channel into the next channel.

Alternatively any number of channels may be summed with the signal at the SUM input socket.

Carrier frequency:	Entire range for selected waveform.
Carrier waveforms:	All standard and arbitrary waveforms.
Sum source:	Internal from the previous channel. External from SUM IN socket.
Frequency Range:	DC to >25MHz.
External Signal Range:	Approximately 5Vpk–pk input for 20Vpk–pk output.

## Inter-channel Synchronisation:

Two or more channels may be synchronised together. Each synchronised channel may be assigned a phase angle relative to the other synchronised channels. Arbitrary waveforms and waveform sequences may be synchronised but certain constraints apply to waveform lengths and clock frequency ratios. With one channel assigned as the Master and other channels as Slaves a frequency change on the master will be repeated on each slave thus allowing multi-phase waveforms at the same frequency to be easily generated.

Channels may be clocked using the master channel, the System Clock or an External Arb Clock.

### Phase Resolution:

DDS waveforms:	0.1 degree
Non-DDS waveforms:	0.1 degree or 360 degrees/number of points whichever is the greater

### Phase Error:

All waveforms:	<± 6ns (internal clock) <± 2ns (External Arb or System Clock)
----------------	--

The signals from the REF IN/OUT socket and the SYNC OUT socket can be used to synchronise two instruments where more than 4 channels are required.

## Inter-channel Triggering:

Any channel can be triggered by the previous or next channel.

The previous/next connections can be used to 'daisy chain' a trigger signal from a 'start' channel, through a number of channels in the 'chain' to an 'end' channel. Each channel receives the trigger out signal from the previous (or next) channel, and drives its selected trigger out to the next (or previous) channel. The 'end' channel trigger out can be set up to drive the 'start' channel, closing the loop.

In this way, complex and versatile inter-channel trigger schemes may be set up. Each channel can have its trigger out and its output waveform set up independently. Trigger out may be selected from Waveform End, Position Markers, Sequence Sync or Burst Done.

## INTERFACES

Full remote control facilities are available through the RS232, USB or GPIB interfaces.

RS232:	Variable Baud rate, 38400 Baud maximum. 9-pin D–connector.
IEEE–488:	Conforms with IEEE488.1 and IEEE488.2
USB	1.1

---

## GENERAL

Display:	20 character x 4 row alphanumeric LCD.
Data Entry:	Keyboard selection of mode, waveform etc.; value entry direct by numeric keys or by rotary control.
Memory Card:	Removable memory card conforming to the Compact Flash memory card standard. Sizes from 32MB to 1GB can be used.
Stored Settings:	Up to 500 complete instrument set-ups may be stored and recalled from the memory card. Up to 500 arbitrary waveforms can also be stored independent of the instrument settings.
Size:	3U (130mm) height; 350mm width (2 and 4 channels), 212mm (½-rack) single channel; 335mm long.
Weight:	7.2 kg. (16 lb), 2 and 4 channels; 4.1kg (9lb) 1 channel.
Power:	220-240V, nominal 50/60Hz; 110-120V or 100V nominal 50/60/400Hz; nominal voltage adjustable internally; operating range $\pm 10\%$ of nominal; 150VA max. for 4 channels, 100VA max. for 2 channel, 60VA max. for 1 channel. Installation Category II.
Operating Range:	+5°C to 40°C, 20–80% RH.
Storage Range:	–20°C to + 60°C.
Environmental:	Indoor use at altitudes up to 2000m, Pollution Degree 2.
Options:	19 inch rack mounting kit.
Safety & EMC:	Complies with EN61010-1 & EN61326-1. For details, request the EU Declaration of Conformity for this instrument via <a href="http://www.aimtti.com/support">http://www.aimtti.com/support</a> (serial no. needed).

This generator is a Safety Class I instrument according to IEC classification and has been designed to meet the requirements of EN61010–1 (Safety Requirements for Electrical Equipment for Measurement, Control and Laboratory Use). It is an Installation Category II instrument intended for operation from a normal single phase supply.

This instrument has been tested in accordance with EN61010–1 and has been supplied in a safe condition. This instruction manual contains some information and warnings which have to be followed by the user to ensure safe operation and to retain the instrument in a safe condition.

This instrument has been designed for indoor use in a Pollution Degree 2 environment in the temperature range 5°C to 40°C, 20% – 80% RH (non–condensing). It may occasionally be subjected to temperatures between +5° and –10°C without degradation of its safety. Do not operate while condensation is present.

Use of this instrument in a manner not specified by these instructions may impair the safety protection provided. Do not operate the instrument outside its rated supply voltages or environmental range.

### **WARNING! THIS INSTRUMENT MUST BE EARTHED**

Any interruption of the mains earth conductor inside or outside the instrument will make the instrument dangerous. Intentional interruption is prohibited. The protective action must not be negated by the use of an extension cord without a protective conductor.

When the instrument is connected to its supply, terminals may be live and opening the covers or removal of parts (except those to which access can be gained by hand) is likely to expose live parts. The apparatus shall be disconnected from all voltage sources before it is opened for any adjustment, replacement, maintenance or repair.

Any adjustment, maintenance and repair of the opened instrument under voltage shall be avoided as far as possible and, if inevitable, shall be carried out only by a skilled person who is aware of the hazard involved.

If the instrument is clearly defective, has been subject to mechanical damage, excessive moisture or chemical corrosion the safety protection may be impaired and the apparatus should be withdrawn from use and returned for checking and repair.

Make sure that only fuses with the required rated current and of the specified type are used for replacement. The use of makeshift fuses and the short–circuiting of fuse holders is prohibited.

This instrument uses a Lithium button cell for non–volatile memory battery back–up; typical life is 5 years. In the event of replacement becoming necessary, replace only with a cell of the correct type, i.e. 3V Li/MnO<sub>2</sub> 20mm button cell type 2032. Exhausted cells must be disposed of carefully in accordance with local regulations; do not cut open, incinerate, expose to temperatures above 60°C or attempt to recharge.

Do not wet the instrument when cleaning it and in particular use only a soft dry cloth to clean the LCD window. The following symbols are used on the instrument and in this manual:–



**Caution** –refer to the accompanying documentation, incorrect operation may damage the instrument.



terminal connected to chassis ground.



mains supply OFF.



mains supply ON.



alternating current.

## Mains Operating Voltage – Single Channel Instrument

Check that the instrument operating voltage marked on the rear panel is suitable for the local supply. Should it be necessary to change the operating voltage, proceed as follows:

- 1) Disconnect the instrument from all voltage sources.
- 2) Remove the screws which retain the top cover and lift off the cover.
- 3) Change the transformer connections following the diagram below. To change the connection, cut the brown wire from the switch at the switch end of the crimped butt connector; make safe the exposed end of the connector. Strip 6mm of insulation from the end of the cut brown wire; fit into the connector for the new supply voltage and crimp. Check that the connection is mechanically secure and that there are no loose strands.

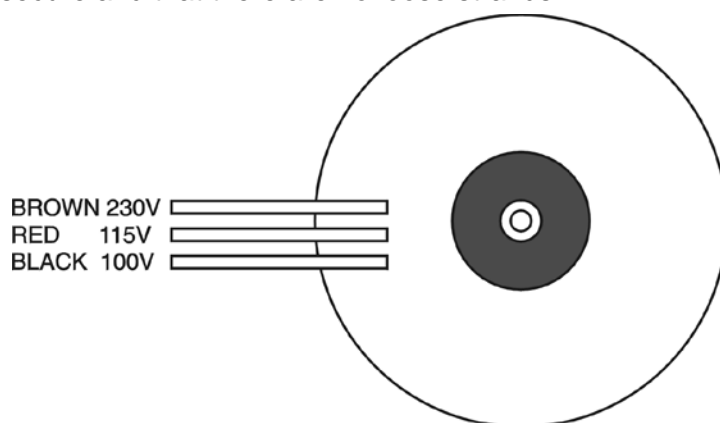

for 230V operation connect the brown transformer wire to the brown wire from the switch  
 for 115V operation connect the red transformer wire to the brown wire from the switch  
 for 100V operation connect the black transformer wire to the brown wire from the switch

- 4) Refit the cover and the secure with the same screws.
- 5) To comply with safety standard requirements the operating voltage marked on the rear panel must be changed to clearly show the new voltage setting.
- 6) Change the fuse to one of the correct rating, see below.

## Mains Operating Voltage – 2- and 4-Channel Instruments

These instruments have a universal input range and will operate from a nominal 100V, 115V or 230V mains supply without adjustment. Check that the local supply meets the AC Input requirement given in the Specification.

### Fuse

Ensure that the correct mains fuse is fitted for the set operating voltage. The correct mains fuse types are:

	<b>230V operation</b>	<b>110V/115V operation</b>
1-channel instrument	500mA(T)250V HRC	1A(T)250V HRC
2- and 4-channel instruments	2A(T)250V HRC	2A(T)250V HRC

To replace the fuse, disconnect the mains lead from the inlet socket and withdraw the fuse drawer below the socket pins. Change the fuse and replace the drawer.

The use of makeshift fuses or the short-circuiting of the fuse holder is prohibited.

---

## **Mains Lead**

Connect the instrument to the AC supply using the mains lead provided. Should a mains plug be required for a different mains outlet socket, a suitably rated and approved mains lead set should be used which is fitted with the required wall plug and an IEC60320 C13 connector for the instrument end. To determine the minimum current rating of the lead-set for the intended AC supply, refer to the power rating information on the equipment or in the Specification.

### **WARNING! THIS INSTRUMENT MUST BE EARTHED**

Any interruption of the mains earth conductor inside or outside the instrument will make the instrument dangerous. Intentional interruption is prohibited. The protective action must not be negated by the use of an extension cord without a protective conductor.

## **Mounting**

This instrument is suitable both for bench use and rack mounting. It is delivered with feet for bench mounting. The front feet include a tilt mechanism for optimal panel angle.

A rack kit for mounting in a 19" rack is available from the Manufacturers or their overseas agents.

## **Ventilation**

The generator uses a fan fitted to the rear panel. Take care not to restrict the rear air inlet or the vents at the front (sides and underneath). In rack-mounted situations allow adequate space around the instrument and/or use a fan tray for forced cooling.



## Front Panel Connections

### MAIN OUT (1 per channel)

This is the 50Ω output from the channel's main generator. It will provide up to 20V peak-to-peak e.m.f. which will yield 10V peak-to-peak into a matched 50Ω load. It can tolerate a short circuit for 60 seconds.



Do not apply an external voltage to this output.

### SYNC OUT (1 per channel)

This is a TTL/CMOS level output which may be set to any of the following signals from the **SYNC OUT** screen.

<b>waveform sync</b>	A sync marker phase coincident with the MAIN OUT waveform. For standard waveforms, (sine, cosine, haversines, square, triangle, sinx/x and ramp), the sync marker is a squarewave with a 1:1 duty cycle with the rising edge at the 0° phase point and the falling edge at the 180° phase point. For arbitrary waveforms the sync marker is a positive pulse coincident with the first few points (addresses) of the waveform.
<b>position marker</b>	When position (pos'n) marker is selected, the instrument generates a pulse marker pattern for arbitrary waveforms. The pulse pattern is programmable from the <b>edit waveform</b> menu on the <b>MODIFY</b> screen.
<b>Burst done</b>	Provides a signal during Gate or Trigger modes which is low while the waveform is active at the main output and high at all other times.
<b>Sequence sync</b>	Provides a signal which is low during the last cycle of the last waveform in a sequence and high at all other times.
<b>Trigger</b>	Provides a positive going version of the actual trigger signal; internal, external, manual and remote all produce a trigger sync.
<b>Sweep sync</b>	Goes high at the start of sweep and remains high for the duration of the first frequency step. In addition, a half-amplitude marker pulse can be set to be output at any of the frequency steps.
<b>Phase lock</b>	Produces a positive edge coincident with the start of the current waveform; this is used for synchronising instruments. This waveform may not appear coherent.

SYNC OUT logic levels are nominally 0V and 5V from typically 50Ω. SYNC OUT will withstand a short circuit.



Do not apply an external voltage to this output.

### TRIG IN

This is the external input for Trigger, Gate, Sweep and Sequence operations. It is also the input used to synchronise the generator (as a slave) to another (which is the master).



Do not apply an external voltage exceeding ±10V.

### SUM IN

This is the input socket for external signal summing. The channel(s) with which this signal is to be summed are selected on the **SUM** screen.



Do not apply an external voltage exceeding ±10V.

---

## MODULATION IN

This is the input socket for external modulation. Any number of channels may be AM or SCM modulated with this signal; the target channels are selected on the **MODULATION** screen.



Do not apply an external voltage exceeding  $\pm 10V$ .

## Rear Panel Connections

### REF CLOCK IN/OUT

The function of the CLOCK IN/OUT socket is set from the **REF/SYS CLOCK** menu on the **UTILITY** screen, see System Operations section.

**input** This is the default setting. The socket becomes an input for an external 10MHz reference clock. The system automatically switches over from the internal clock when the external reference is applied.

**output** The internal 10MHz clock is made available at the socket.

**master/slave** When two or more generators are synchronised the slaves are set to **slave** and the master is set to **master**.

As an output the logic levels are nominally 1V and 4V from typically 50 $\Omega$ . CLOCK OUT will withstand a short-circuit. As an input the threshold is TTL/CMOS compatible.



Do not apply external voltages exceeding + 5V or -1V to this signal connection.

### HOLD IN

Controls the waveform hold function. The input impedance is nominally 10k $\Omega$ .



Do not apply an external voltage exceeding  $\pm 10V$ .

### ARB CLOCK IN/OUT

Set to an Input, this is the input for a user-supplied ARB clock in the frequency range DC to 50MHz.

Set to an Output, it outputs the System Clock at TTL/CMOS compatible logic levels.



Do not apply an external voltage exceeding + 5V or -1V.

### MAIN OUT (1 per channel)

These plugged panel positions are provided for the user to fit a 50 $\Omega$  BNC as an **alternative** to each front panel MAIN OUT socket where rear panel connections are required in a rack-mounted system. The front panel MAIN OUT connection must be carefully disconnected from the pcb and the pcb then rewired, using high quality 50 $\Omega$  coax, to the new rear panel connector.



Do not apply an external voltage to these outputs.

---

## RS232

9-pin D-connector compatible with addressable RS232 use. The pin connections are shown below:

Pin	Name	Description
1	–	No internal Connection
2	TXD	Transmitted data from instrument
3	RXD	Received data to instrument
4	–	No internal connection
5	GND	Signal ground
6	–	No internal connection
7	RXD2	Secondary received data
8	TXD2	Secondary transmitted data
9	GND	Signal ground

Pin 2, 3 and 5 may be used as a conventional RS232 interface with XON/XOFF handshaking. Pins 7, 8 and 9 are additionally used when the instrument is used in addressable RS232 mode. Signal grounds are connected to instrument ground. The RS232 address is set from the **remote** menu on the **UTILITY** screen, see System Operations section.

## GPIB (IEEE-488)

The GPIB interface is not isolated; the GPIB signal grounds are connected to the instrument ground.

The implemented subsets are:

SH1 AH1 T6 TE0 L4 LE0 SR1 RL1 PP1 DC1 DT1 C0 E2

The GPIB address is set from the **remote** menu on the **UTILITY** screen, see System Operations section.

## USB

The USB port is connected to instrument ground. It accepts a standard USB cable. If USB has been selected as the current interface and the driver has been installed from the CD, the Windows plug-and-play function should automatically recognise that the instrument has been connected. See the USB folder on the CD for information on installing the driver on a PC.

## MEMORY CARD

The MEMORY CARD slot accepts a standard Compact Flash Card, size 32MB to 1GB. The 'Memory Card Active' lamp on the front panel is lit during memory card reads and writes.

## Initial Operation

This section is a general introduction to the organisation of the instrument and is intended to be read before using the generator for the first time. Detailed operation is covered in later sections starting with Standard Waveform Operation.

In this manual front panel keys and sockets are shown in capitals, e.g. CREATE, SYNC OUT; all soft-key labels, entry fields and messages displayed on the LCD are shown in a different type-font, e.g. **STANDARD WAVEFORMS**, **sine**.

## Switching On

The power switch is located at the bottom left of the front panel.

At power up the generator displays the installed software revision whilst loading its waveform RAM; if an error is encountered the message **system ram error, battery fault or firmware updated** will be displayed, see the Warnings and Error Messages section.

Loading takes a few seconds, after which the status screen is displayed, showing the generator parameters set to their default values, with the MAIN OUT outputs set off. Refer to the System Operations section for how to change the power up settings to either those at power down or to any one of the stored settings. Recall the status screen at any time with the STATUS key; a second press returns the display to the previous screen.

On multi-channel instruments the status shown is that of the channel selected by the SETUP keys; this is the channel currently enabled for editing and is always the last channel selected whether power has been switched off or not. Change the basic generator parameters for the selected channel as described in the Standard Waveform Operation section and switch the output on with the MAIN OUT key; the ON lamp will light to show that the output is on.

## Display Contrast

All parameter settings are displayed on the 20 character x 4 row backlit liquid crystal display (LCD). The contrast may vary a little with changes of ambient temperature or viewing angle but can be optimised for a particular environment by using the front panel contrast control. Insert a small screwdriver or trimmer tool through the adjustment aperture marked LCD and rotate the control for optimum contrast.

## Keyboard

Pressing the front panel keys displays screens which list parameters or choices relative to the key pressed. Selections are then made using the display soft-keys and numeric values are changed using the numeric keys or rotary control, see the Principles of Editing section.

The keys are grouped as follows:

- WAVE SELECT keys call screens from which all standard or already defined arbitrary waveforms can be selected.
- WAVE EDIT keys call screens from which arbitrary waveforms can be created and modified.
- FREQUENCY, AMPLITUDE, OFFSET and MODE keys display screens which permit their respective parameters to be edited either from the numeric keypad or using the rotary control/cursor keys.
- Numeric keys permit direct entry of a value for the parameter currently selected. Values are accepted in three formats: integer (20), floating point (20.0) and exponential (2 EXP 1). For example, to set a new frequency of 50kHz press FREQ followed by 50000 ENTER or 5 EXP 4 ENTER. ENTER confirms the numeric entry and changes the generator setting to the new value.  
CE (Clear Entry) undoes a numeric entry digit by digit. ESCAPE returns a setting being edited to its last value.

- MODULATION, SUM, TRIG IN and SYNC OUT call screens from which the parameters of those input/outputs can be set, including whether the port is on or off.
- SWEEP and SEQUENCE similarly call screens from which all parameters can be set and the functions run.
- Each channel has a key which directly switches the MAIN OUT of that channel on and off.
- MAN TRIG is used for manual triggering (when TRIG IN is appropriately set) and for synchronising two or more generators when suitably connected together. MAN HOLD is used to manually pause arbitrary waveform output and sweep; the output is held at the level it was at when MAN HOLD was pressed.
- UTILITY gives access to menus for a variety of functions such as remote control interface set-up, power-up parameters, error message settings and store/recall settings to/from memory card; the STORE and RECALL keys can also be used to directly access the memory card settings files.
- The INTER CHannel and COPY CHannel keys (multi-channel instruments only) directly call screens from which channel-to-channel synchronisation and set-up copying can be set.
- The SETUP keys (multi-channel instruments only) select the channel to be edited; the lamp lights beside the channel currently enabled for editing.
- Eight soft-keys around the display are used to directly set or select parameters from the currently displayed menu; their operation is described in more detail in the next section.
- The STATUS key always returns the display to the default start-up screen which gives an overview of the generators status. Pressing STATUS again returns the display to the previous screen.

Further explanations will be found in the detailed descriptions of the generator's operation.

## Principles of Editing

Each screen called up by pressing a front panel key shows parameter value(s) and/or a list of choices. Parameter values can be edited by using the ROTARY CONTROL in combination with the left and right arrowed CURSOR keys, or by direct numeric keyboard entry; choices are made using the soft-key associated with the screen item to be selected. The examples which follow assume factory default settings.

**The channel to be edited must first be selected by pressing the appropriate SETUP key; the lamp lights beside the SETUP key of the channel currently enabled for editing.**

A diamond beside a screen item indicates that it is selectable; hollow diamonds identify deselected items and filled diamonds denote selected items. For example, press MODE to get the screen shown below:

```

MODE:
◆continuous
◇gated      setup...◇
◇triggered  setup...◇

```

The filled diamond indicates that the selected mode is **continuous**. **Gated** or **Triggered** modes are selected by pressing the associated soft-key which will make the diamond beside that item filled and the diamond beside **continuous** hollow. This screen also illustrates how an ellipsis (three dots following the screen text) indicates that a further screen follows when that item is selected. In the case of the MODE screen illustrated, pressing the **setup...** soft-key on the bottom line brings up the **TRIGGER SETUP** menu; note that selecting this item does not change the **continuous/gated/triggered** selection.

Some screen items are marked with a double-headed arrow (a split diamond) when selected to indicate that the item's setting can be changed by further presses of the soft-key, by pressing either cursor key or by using the rotary control. For example, pressing FILTER brings up the screen shown below.

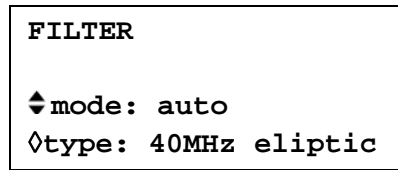

Repeated presses of the **mode** soft-key will toggle the mode between its two possible settings of **auto** and **manual**. Similarly, when **type** is selected, repeated presses of the **type** soft-key (or cursor keys or use of the rotary control) will step the selection through all possible settings of the filter type.

In addition to their use in editing items identified by a double-headed arrow as described above, the CURSOR keys and ROTARY CONTROL operate in two other modes.

In screens with lists of items that can be selected (i.e. items marked with a diamond) the cursor keys and rotary control are used to scroll all items through the display if the list has more than three items; look, for example at the STD (standard waveform) and UTILITY screens.

In screens where a parameter with a numeric value is displayed the cursor keys move the edit cursor (a flashing underline) through the numeric field and the rotary control will increment or decrement the value; the step size is determined by the position of the edit cursor within the numeric field.

Thus for **STANDARD FREQUENCY** set to **1.00000000 MHz** rotating the control will change the frequency in 1kHz steps. The display will auto-range up or down as the frequency is changed, provided that autoranging permits the increment size to be maintained; this will in turn determine the lowest or highest setting that can be achieved by turning the control. In the example above, the lowest frequency that can be set by rotating the control is 1 kHz, shown on the display as **1.00000000 kHz**.

This is the limit because to show a lower frequency the display would need to autorange below 1kHz to **xxx.xxxxxxx Hz** in which the most significant digit represents 100Hz, i.e. the 1kHz increment would be lost. If, however, the starting frequency had been set to **1.00000000 MHz**, i.e. a 100 Hz increment, the display would have autoranged at 1kHz to **900.000000 Hz** and could then be decremented down to **100.000000 Hz** without losing the 100 Hz increment.

Turning the control quickly will step numeric values in multiple increments.

## Principles of Operation

The instrument operates in one of two different modes depending on the waveform selected. DDS mode is used for sine, cosine, haversine, triangle, sinx/x and ramp waveforms. Clock Synthesis mode is used for square, pulse, pulse train, arbitrary and sequence.

In both modes the waveform data is stored in RAM. As the RAM address is incremented the values are output sequentially to a Digital-to-Analogue Converter (DAC) which reconstructs the waveform as a series of voltages steps which are subsequently filtered before being passed to the main output connector.

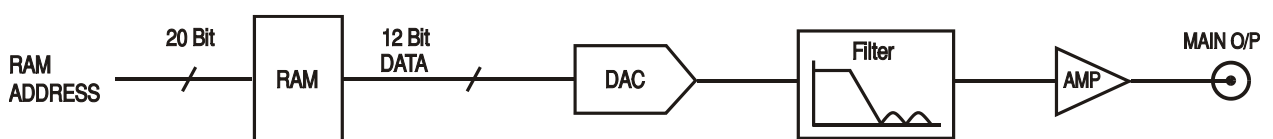

The main differences between DDS and Clock Synthesis modes are the way in which the addresses are generated for the RAM and the length of the waveform data.

## Clock Synthesis Mode

In Clock Synthesis mode the addresses are always sequential (an increment of one) and the clock rate is adjusted by the user in the range 100MHz to 0.1Hz. The frequency of the waveform is clock frequency  $\div$  waveform length, thus allowing short waveforms to be played out at higher repetition rates than long waveforms, e.g. the maximum frequency of an 8 point waveform is  $100 \times 10^6 \div 8$  or 12.5 MHz but a 1000 point waveform has a maximum frequency of  $100 \times 10^6 \div 1000$  or 100kHz.

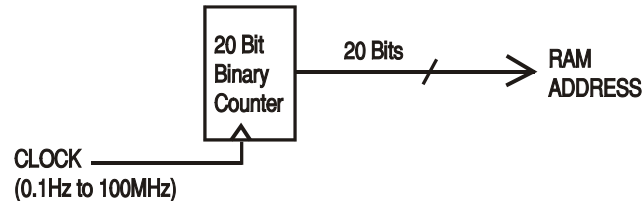

Arbitrary waveforms have a user defined length of 8 to 1048576 points. Squarewaves use a fixed length of 2 points and pulse and pulse train have their length defined by the user selected period value.

## DDS Mode

In DDS mode (Direct Digital Synthesis) all waveforms are stored in RAM as 4096 points. The frequency of the output waveform is determined by the rate at which the RAM addresses are changed. The address changes are generated as follows:

The RAM contains the amplitude values of all the individual points of one cycle (360°) of the waveform; each sequential address change corresponds to a phase increment of the waveform of  $360^\circ/4096$ . Instead of using a counter to generate sequential RAM addresses, a phase accumulator is used to increment the phase.

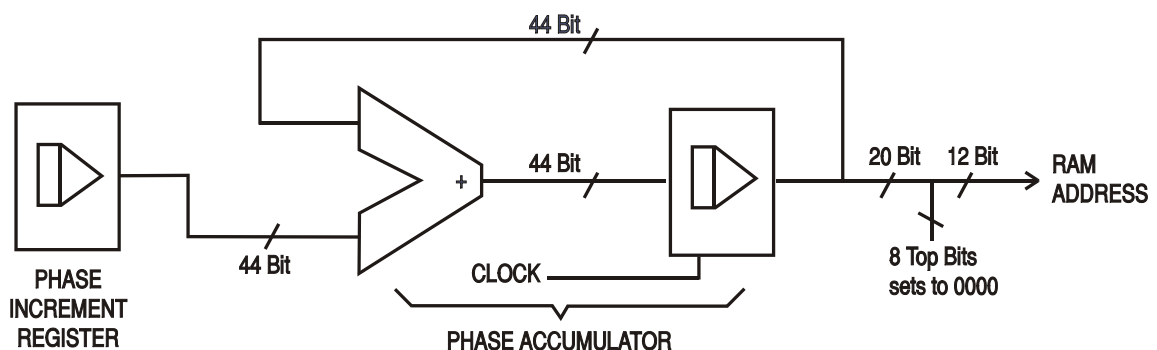

On each clock cycle the phase increment, which has been loaded into the phase increment register by the CPU, is added to the current result in the phase accumulator; the 12 most significant bits of the phase accumulator drive the lower 12 RAM address lines, the upper 8 RAM address lines are held low. The output waveform frequency is now determined by the size of the phase increment at each clock. If each increment is the same size then the output frequency is constant; if it changes, the output frequency changes as in sweep mode.

The generator uses a 44 bit accumulator and a 100 MHz clock frequency; the frequency setting resolution is 0.1 mHz.

Only the 12 most significant bits of the phase accumulator are used to address the RAM. At a waveform frequency of  $F_{CLK}/4096$  (~24.4kHz), the natural frequency, the RAM address increments at every clock. At all frequencies below this (i.e. at smaller phase increments) one or more addresses are output for more than one clock period because the phase increment is not big enough to step the address at every clock. Similarly at frequencies above the natural frequency the larger phase increment causes some addresses to be skipped, giving the effect of the stored waveform being sampled; different points will be sampled on successive cycles of the waveform.

---

## Standard Waveform Operation

This section deals with the use of the instrument as a standard function generator, i.e. generating sine, square, triangle, dc, ramp, haversine, cosine, havercosine and  $\sin x/x$  waveforms. All but squarewave are generated by DDS which gives 10–digit frequency resolution; squarewave is generated by Clock Synthesis which results in only 8–digit frequency resolution. Refer to Principles of Operation in the previous section for a fuller explanation of the differences involved.

The **STANDARD WAVEFORMS** screen also includes arbitrary and sequence for simplicity of switching between these and standard waveforms; they do, however, have their own screens (accessed by pressing ARB and SEQUENCE respectively) and are described in detail in their appropriate sections. Pulse and pulse–train are also accessed from the ‘standard waveforms’ screen but are sufficiently different to justify their own section in the manual.

Much of the following descriptions of amplitude and offset control, as well as of Mode, Sweep, etc., in following sections, apply to arbitrary and sequence as well as standard waveforms; for clarity, any differences of operation with arbitrary, sequence, pulse and pulse–train are described only in those sections.

### Setting Generator Parameters

#### Waveform Selection

```
STANDARD WAVEFORMS
◆sine
◇square
◇triangle
```

Pressing the STD key gives the **STANDARD WAVEFORMS** screen which lists all the waveforms available; the rotary control or cursor keys can be used to scroll the full list back and forward through the display. The currently selected waveform (sine with the factory defaults setting) is indicated by the filled diamond; the selection is changed by pressing the soft–key beside the required waveform.

#### Frequency

```
STANDARD FREQUENCY
10.00000000 kHz
◆freq          period◇
```

Pressing the FREQ key gives the **STANDARD FREQUENCY** screen. With **freq** selected as shown above, the frequency can be entered directly from the keyboard in integer, floating point or exponential format, e.g. 12.34 kHz can be entered as 12340, 12340.00, or 1.234 exp 4 etc. However, the display will always show the entry in the most appropriate engineering units, in this case 12.34000000 kHz.

With **period** selected instead of **freq** the frequency can be set in terms of a period, e.g. 123.4 $\mu$ s can be entered as .0001234 or 123.4e–6; again the display will always show the entry in the most appropriate engineering units.

Squarewave, generated by Clock Synthesis has 8–digit resolution for both frequency and period entry.

Turning the rotary control will increment or decrement the numeric value in steps determined by the position of the edit cursor (flashing underline); the cursor is moved with the left and right arrowed cursor keys.

Note that the upper frequency limits vary for the different waveform types; refer to the Specifications section for details.



---

## Amplitude

```
AMPLITUDE:
      +20·0  Vpp
◆Vpp          Vrms ◇
◇dBm          load:hiZ ◇
```

Pressing the AMPL key gives the **AMPLITUDE** screen.

The waveform amplitude can be set in terms of peak-to-peak Volts (Vpp), r.m.s. Volts (Vrms) or dBm (referenced to a 50Ω or 600Ω load). For Vpp and Vrms the level can be set assuming that the output is open-circuit (**load:hiZ**) or terminated (**load:50Ω** or **load:600Ω**); when dBm is selected termination is always assumed and the **load:hiZ** setting is automatically changed to **load:50Ω**. Note that the actual generator output impedance is always 50Ω; the displayed amplitude values for 600Ω termination take this into account.

With the appropriate form of the amplitude selected (indicated by the filled diamond) the amplitude can be entered directly from the keyboard in integer, floating point or exponential format, e.g. 250mV can be entered as .250 or 250 exp -3, etc.,. However, the display will always show the entry in the most appropriate engineering units, in this case 250mV.

Turning the rotary control will increment or decrement the numeric value in steps determined by the position of the edit cursor (flashing underline); the cursor is moved with the left and right arrowed cursor keys.

Alternate presses of the ± key will invert the MAIN OUT output; if DC OFFSET is non-zero, the signal is inverted about the same offset. The exception to this is if the amplitude is specified in dBm; since low level signals are specified in -dBm (0dBm = 1mW into 50Ω = 224mVrms) the - sign is interpreted as part of a new amplitude entry and not as a command to invert the signal.

Note that for DC, sinx/x, pulse, pulse train, arbitrary and sequence amplitude can only be displayed and entered in the Vpp form; further limitations on pulse, pulse-train, arbitrary and sequence amplitude are discussed in the appropriate sections.

## DC Offset

```
DC OFFSET:
program +0·00 mVdc
(actual +0·00 mVdc)
      load:hiZ ◇
```

Pressing the OFFSET key gives the **DC OFFSET** screen. The offset can be entered directly from the keyboard in integer, floating point or exponential format, e.g. 100mV can be entered as .1 or 100 exp -3 etc. However, the display will always show the entry in the most appropriate engineering units, in this case 100mV. During a new offset entry the ± key can be used at any time to set the offset negative; alternate presses toggle the sign between + and -.

Turning the rotary control will increment or decrement the numeric value in steps determined by the position of the edit cursor (flashing underline); the cursor is moved by the left and right arrowed cursor keys. Because DC offset can have negative values, the rotary control can take the value below zero; although the display may autorange to a higher resolution if a step takes the value close to zero, the increment size is maintained correctly as the offset is stepped negative. For example, if the display shows

```
program = +205· mVdc
```

with the cursor in the most significant digit, the rotary control will decrement the offset in 100mV steps as follows:

```
program = +205· mVdc
program = +105· mVdc
```

---

```
program = +5.00 mVdc
program = -95.0 mVdc
program = -195. mVdc
```

The actual DC offset at the MAIN OUT socket is attenuated by the fixed-step output attenuator when this is in use. Since it is not obvious when the signal is being attenuated the actual offset is shown in brackets as a non-editable field below the programmed value.

For example, if the amplitude is set to 2.5Vpp the output is not attenuated by the fixed attenuator and the actual DC offset (in brackets) is the same as that set. The **DC OFFSET** display shows:

```
DC OFFSET:
program +1.50 Vdc
(actual +1.50 Vdc)
load: hiZ◇
```

If the amplitude is now reduced to 250mVpp which introduces the attenuator, the actual DC offset changes by the appropriate factor:

```
DC OFFSET:
program +1.50 Vdc
(actual +151. mVdc)
load: hiZ◇
```

The above display shows that the set DC offset is +1.50V but the actual offset is +151mV. Note that the actual offset value also takes into account the true attenuation provided by the fixed attenuator, using the values determined during the calibration procedure. In the example displayed the output signal is 250mVpp exactly and takes account of the small error in the fixed attenuator; the offset is 151.mV exactly, taking account of the effect of the known attenuation (slightly less than the nominal) on the set offset of 1.50V.

Whenever the set DC offset is modified by a change in output level in this way a warning message that this has happened will be displayed. Similarly, because the DC offset plus signal peak is limited to  $\pm 10V$  to avoid waveform clipping, a warning message will be displayed if this condition is set. This is explained more fully in the Warnings and Error Messages section.

The output attenuation is controlled intelligently to minimise the difference between the programmed and actual offset when the combination of programmed amplitude and offset allows this. Thus when the offset is set to 150mV, for example, the amplitude can be reduced to nominally 50mVpp before the fixed attenuator causes the actual offset to be different from the programmed value.

## Warnings and Error Messages

Two classes of message are displayed on the screen when an illegal combination of parameters is attempted.

WARNING messages are shown when the entered setting causes some change which the user might not necessarily expect. Examples are:

1. Changing the amplitude from, for example, 2.5 Volts pk-pk to 25mV pk-pk brings in the step attenuator; if a non-zero offset has been set then this will now be attenuated too. The message **DC offset changed by amplitude** will be shown temporarily on the screen but the setting will be accepted; in this case the actual, attenuated, offset will be shown in brackets below the set value.

- 
2. With the output level set to 10V pk-pk, increasing the DC offset beyond  $\pm 5V$  will cause the message **Offset + sum + level may cause clipping**. The offset change will be accepted (producing a clipped waveform) and the user may then choose to change the output level or the offset to produce a signal which is not clipped. (**clip?**) will show in the display beside **AMPLITUDE** or **DC OFFSET** while the clipped condition exists.

ERROR messages are shown when an illegal setting is attempted, most generally a number outside the range of values permitted. In this case the entry is rejected and the parameter setting is left unchanged. Examples are:

1. Entering a frequency of 1MHz for a triangle waveform. The error message:  
**Frequency out of range for the selected waveform** is shown.
2. Entering an amplitude of 25Vpp. The error message:  
**Maximum output level exceeded** is shown.
3. Entering a DC offset of 20V. The error message:  
**Maximum DC offset value exceeded** is shown.

The messages are shown on the display for approximately two seconds. The last two messages can be viewed again by pressing the **last error...** soft-key on the UTILITY screen, see Memory Card and System Operations section.

Each message has a number and the full list appears in Appendix 1.

The default set-up is for all warning and error messages to be displayed and for a beep to sound with each message. This set-up can be changed on the **error...** menu on the UTILITY screen. The **error** menu is shown below:

```
◇error beep: ON
◇error message: ON
◆warn beep: ON
◇warn message: ON
```

Each feature can be turned ON and OFF with alternate presses of the associated soft-key; the factory default is for all features to be ON.

## SYNC Output

SYNC OUT is a multifunction CMOS/TTL level output that can be automatically or manually set to be any of the following:

- **waveform sync** : A square wave with 50% duty cycle at the main waveform frequency, or a pulse coincident with the first few points of an arbitrary waveform. Can be selected for all waveforms.
- **position marker** : If an arbitrary waveform is selected, any point(s) on that waveform may have associated marker bit(s) set high or low. These will then show as pulses when **position marker** is selected.
- **burst done** : Produces a pulse coincident with the last cycle of the burst.
- **sequence sync** : Produces a pulse coincident with the end of a waveform sequence.
- **trigger** : Selects the current trigger signal (internal, external or manual). Useful for synchronising burst or gated signals.
- **sweep sync** : Outputs the sweep trigger and sweep marker signals.
- **phase lock** : Used to synchronise two or more generators. Produces a positive edge at the  $0^\circ$  phase point.

---

The setting up of the signals themselves is discussed in the relevant sections later in this manual, e.g. **trigger** is described in the Triggered Burst/Gate section and **position marker** under the Arbitrary Waveform Generation.

Pressing the SYNC OUT key calls the **SYNC OUT** setup screen.

```
SYNC OUT:  
▲output: on  
◇mode: auto  
▲src: waveform sync
```

SYNC OUT is turned on and off by alternate presses of the **output** soft-key.

The selection of the signal to be output from the SYNC OUT socket is made using the **src** (source) soft-key; repeated presses of **src** cycle the selection through all the choices (**waveform sync**, **position marker**, etc.) listed above. Alternatively, with the **src** selected (double-headed arrow) the rotary control or cursor keys can be used to step backwards and forwards through the choices.

The source selection of the SYNC OUT waveform can be made automatic (**auto**) or user-defined (**manual**) with alternate presses of the **mode** soft-key. In automatic mode the SYNC OUT waveform most appropriate for the current main waveform is selected.

For example, **waveform sync** is automatically selected for all continuous standard and arbitrary waveforms, but **trigger** is selected in trigger or gated waveform modes. The automatic selection will be mentioned in each of the appropriate main waveform mode sections and a full table is given in Appendix 2.

The automatic selection can still be changed manually by the **src** soft-key even when **auto** mode has been selected but the selection will immediately revert to the automatic choice as soon as any relevant parameter (e.g. main waveform frequency or amplitude) is adjusted. **Manual** must be selected by the **mode** soft-key for a source other than the automatic choice to remain set. The **auto** selection will generally set the most frequently used signal, e.g. **waveform sync** for all continuous main waveforms, but **manual** will need to be used for special requirements, e.g. position markers on arbitrary waveforms.

## General

### Principles of Sweep Operation

All standard and arbitrary waveforms can be swept with the exception of pulse, pulse-train and sequence. During Sweep all waveforms are generated in DDS mode because this offers the significant advantage of phase-continuous sweeps over a very wide frequency range (up to  $10^{10}$ ). However, it must be remembered that the frequency is actually stepped, not truly linearly swept, and thought needs to be given as to what the instrument is actually doing when using extreme combinations of sweep range and time.

For DDS operation during Sweep all waveforms must be 4096 points in length; this is the natural length for standard waveforms but all arbitrary waveforms are expanded or condensed in software to 4096 points when Sweep is turned on. This does not affect the original data.

Sweep mode is turned on and off either by the **on** or **off** soft-key on the **SWEEP SETUP** screen accessed by pressing the SWEEP front panel key, or by the **sweep** soft-key on the **MODE** screen. In multi-channel instruments two or more channels can be swept at once.

When sweep is turned on the software creates a table of 2000 frequencies between, and including, the specified start and stop values. Because any frequency used in sweep mode must be one of the tabled values, the centre frequency displayed (see Sweep Range) may not be the exact mid-point and markers (see Sweep Marker) may not be exactly at the programmed frequency. The frequency resolution of the steps will be particularly coarse with wide sweeps.

### Connections for Sweep Operation. Sync Out and Trig In

Sweeps are generally used with an oscilloscope or hard-copy device to investigate the frequency response of a circuit. The MAIN OUT is connected to the circuit input and the circuit output is connected to an oscilloscope or, for slow sweeps, a recorder.

An oscilloscope or recorder can be triggered by connecting its trigger input to the generator's SYNC OUT; SYNC OUT defaults to **sweep sync** when sweep is turned on. **sweep sync** goes high at the start of sweep and remains high for the duration of the first frequency step.

To show a marker on the display instrument the SYNC OUT can be set to additionally output a marker pulse. See Sweep Marker section for setting marker frequency.

For triggered sweeps, a trigger signal may be provided by any of the possible trigger sources, i.e. internal, external, manual or remote.

The generator does not provide a ramp output for use with X-Y displays or recorders.

### Setting Sweep Parameters

Pressing the SWEEP key (or the **sweep setup** soft-key on the **MODE** screen) displays the **SWEEP SETUP** screen.

```
SWEEP SETUP:  off ◆
◆range...    type...◆
◆time...     spacing...◆
               marker...◆
```

Menus for setting up the range, time (sweep rate), type (continuous, triggered, etc.) spacing (lin/log) and marker position are all accessed from this screen using the appropriate soft-key. In addition Sweep Mode itself is turned on and off with alternate presses of the **on/off** soft-key; sweep can also be turned on by the **sweep** soft-key on the **MODE** screen.

---

In multi-channel instruments two or more channels can be swept at once. The channels to be swept are set on or off by selecting them in turn with the appropriate **SETUP** key and then using the **on/off** soft-key of the **SWEEP SETUP** screen. On all the following menus, pressing the **done** soft-key returns the display to this **SWEEP SETUP** screen.

## Sweep Range

Pressing the **range...** soft-key calls the **SWEEP RANGE** screen.

```
SWEEP RANGE:
◆start: 100.0    kHz
◇stop:  10.00   MHz
◇centr/span    done◇
```

The maximum sweep range for all waveforms is 1mHz to 40MHz, including triangle, ramp and squarewave which have different limits in unswept operation.

Sweep range can be defined by start and stop frequencies or in terms of a centre frequency and span. **Start** and **Stop** soft-keys permit the two end points of the sweep to be set directly from the keyboard or by using the rotary control; the start frequency must be lower than the stop frequency (but see Sweep Type for selecting sweep direction).

Pressing the **centr/span** soft-key changes the screen to permit entry in terms of **centr** frequency and sweep **span** about that frequency; pressing the **start/stop** soft-key on that screen returns the display to the start and stop frequency form of entry.

Note that when the sweep is displayed in terms of centre frequency and span the span will always be the exact difference between start and stop frequencies but the centre frequency shown will be that of the frequency step nearest the true centre frequency, see Principles of Sweep Operation section.

## Sweep Time

Pressing the **time...** soft-key calls the **SWEEP TIME** screen.

```
SWEEP TIME:
      0.010 sec
                        done◇
```

The sweep time can be set from 1ms to 999s with 4-digit resolution by direct keyboard entry or by using the rotary control.

## Sweep Type

Pressing the **type** soft-key calls the **SWEEP TYPE** screen.

```
SWEEP TYPE:
◆continuous
◇direction: up
◇sync: on    done◇
```

This screen is used to set the sweep mode (continuous; triggered; triggered, hold and reset) and sweep direction.

Successive presses of the **direction** soft-key select one of the following sweep directions:

- |                |  |
|----------------|--|
| <b>up</b>      | start frequency to stop frequency.                             |
| <b>down</b>    | stop frequency to start frequency.                             |
| <b>up/down</b> | start frequency to stop frequency and back to start frequency. |
| <b>down/up</b> | stop frequency to start frequency and back to stop frequency.  |

---

The total sweep time is always that set on the **SWEEP TIME** screen, i.e. for **up/down** and **down/up** operation the sweep time in each direction is half the total. Similarly the total number of steps is the same for all choices, i.e. there will be half the number of steps in each direction for **up/down** and **down/up** operation. In the sweep mode descriptions which follow the direction is assumed to be **up** but all modes can be used with all sweep directions.

In **continuous** mode the generator sweeps continuously between the start and stop frequencies, triggered repetitively by an internal trigger generator whose frequency is determined by the sweep time setting. At the stop frequency the generator resets to the start frequency and begins a new sweep. If **sync** is set to **on** (the default) the generator actually steps immediately from the stop frequency to zero frequency (i.e. it does not dwell at the stop frequency for the full step interval) and then starts the next sweep from the first point of the waveform, synchronised to the (internally generated) trigger signal.

This is useful because the sweep always starts from the same point in the waveform but the waveform discontinuity can be undesirable in some circumstances, e.g. filter evaluation. With **sync** set to **off**, the frequency steps directly and phase continuously from the stop frequency to the start frequency (after dwelling at the Stop frequency for the full step interval) but is not synchronised to the software-generated trigger signal.

In **triggered** mode the generator holds the output at the start frequency until it recognises a trigger. When triggered, the frequency sweeps to the stop frequency, resets, as follows, and awaits the next trigger. If **sync** is set to **on** the frequency resets to zero frequency (i.e. no waveform) and starts a new sweep at the first point of the waveform when the next trigger is recognised. If **sync** is set to **off** the waveform resets to the start frequency and runs at that frequency until the next trigger initiates a new sweep.

In **trig'd,hold/reset** mode the generator holds the output at the start frequency until it recognises a trigger; when triggered, the frequency sweeps to the stop frequency and holds. At the next trigger the output is reset to the start frequency where it is held until the next sweep is initiated by a further trigger. If **sync** is set to **off** the output operates exactly as described above; if **sync** is set to **on** the frequency actual goes to zero at the start and begins each new sweep at the first point of the waveform.

For triggered sweeps, a trigger signal may be provided by any of the possible trigger sources, i.e. internal, external, manual or remote.

The generator does not provide a ramp output for use with X–Y displays or recorders.

## Sweep Spacing

Pressing the **spacing...** soft-key on the **SWEEP SETUP** screen calls the **SWEEP SPACING** screen.

```
SWEEP SPACING:
◆logarithmic
◇linear
done◇
```

With **linear** selected the sweep changes the frequency at a linear rate; with **logarithmic** selected the sweep spends an equal time in each frequency decade.

## Sweep Marker

A sweep marker pulse is also available from the SYNC OUT socket when **sweep sync** (the default condition) is selected. The marker pulse is differentiated from the sweep sync pulse by being approximately half the amplitude of the sync pulse; this permits the trigger level of the display oscilloscope to be adjusted for the sweep sync pulse without additionally triggering on the marker pulse.

---

The marker pulse frequency is set from the **SWEEP MARKER FREQ** menu, called by pressing the **marker...** soft-key on the **SWEEP SETUP** screen.

```
SWEEP MARKER FREQ:
progm: 5.000      MHz
actual: 4.977      MHz
                        done ◊
```

A new marker frequency can be programmed directly from the keyboard or by using the rotary control and cursor keys. Note that the marker frequency can only be one of the values in the sweep frequency table; any value in the sweep range can be entered but the actual value will be the nearest frequency in the table. When sweep is turned on, the actual marker frequency is shown in the non-editable field below the programmed frequency. For the default sweep setting of 100kHz to 10MHz in 50ms, the actual frequency of a 5MHz marker is 4.998 MHz.

The marker duration is Sweep time/2000, i.e. the dwell time at a single frequency step.

To avoid displaying a sweep marker, the marker frequency is simply set to a value outside the current sweep frequency range.

### **Sweep Hold**

The sweep can be held/restarted at any time at/from its current frequency by alternate presses of the MAN HOLD key or remote command.



## General

Triggered Burst and Gated modes are selected from the **MODE** screen, called by the MODE key, as alternatives to the default continuous mode.

```
MODE:
◆continuous
◇gated      setup...◇
◇triggered  setup...◇
```

In Triggered Burst mode a defined number of cycles are generated following each trigger event. This mode is edge triggered.

In gated mode the generator runs whenever the gating signal is true. This mode is level sensitive.

Triggered Burst mode and Gated mode can be controlled by either the Internal Trigger Generator, an external trigger input, the (internal) Trigger Out signal from an adjacent channel on a multi-channel instrument, by the front panel MAN TRIG key or by remote control.

In both modes the start phase, i.e. the starting point on the waveform cycle, can be specified.

## Internal Trigger Generator

The period of the Internal Trigger Generator is set with the **period** soft-key on the **TRIGGER IN** set-up screen called by the TRIG IN key.

```
◆source: int force ◇
◇slope:  positive
◇level:  +1.4 V
◇period: 1.00ms
```

The Internal Trigger Generator divides down a crystal oscillator to produce a 1:1 square wave with a period from 0.01ms (100kHz) to 200s (.005Hz). Generator period entries that cannot be exactly set are accepted and rounded up to the nearest available value, e.g. .109ms is rounded to .11ms.

When Triggered Burst or Gated modes are selected the SYNC OUT source automatically defaults to **trigger** which is the output of the internal trigger generator when internal triggering or gating is specified.

In Triggered Burst mode the selected edge of each cycle of the trigger generator is used to initiate a burst; the interval between bursts is therefore 0.01ms to 200s as set by the generator period.

In Gated mode the output of the main generator is gated on whilst the Internal Trigger Generator output is true; the duration of the gate is therefore .005ms to 100s in step with trigger generator periods of .01ms to 200s.

## External Trigger Input

External trigger or gate signals are applied to the front panel TRIG IN socket which has a variable threshold level set using the **level** soft-key; the level can be set from -5.0V to +5.0V by direct keyboard entry or by using the rotary control. In Triggered Burst mode the input is edge sensitive; the selected edge of each external trigger initiates the specified burst. In Gated mode the input is level sensitive; the output of the main generator is on whilst the gate signal is true.

The minimum pulse width that can be used with TRIG IN in Triggered Burst and Gated mode is 50ns and the maximum repetition rate is 1MHz. The maximum signal level that can be applied without damage is  $\pm 10V$ .

---

When Triggered Burst or Gated modes are selected the SYNC OUT source automatically defaults to **trigger** which is always a positive–edged version of the external trigger or gate signal when external triggering or gating is specified.

## Adjacent Channel Trigger Output

On multi–channel instruments the Trigger Out signal of an adjacent channel can be used as the control signal for a Triggered Burst. The channel numbering ‘wraps round’, i.e. channels 1 and 3 are obviously adjacent to channel 2 but so are channels 2 and 4 adjacent to channel 1.

The source of the Trigger Out signal is selected by the **source** soft–key on the **TRIGGER OUT** screen called by the TRIG OUT key.

```
TRIGGER OUT:
◆mode: auto
◆source: wfm end
```

The Trigger Out choices are as follows:

- wfm end:** Waveform end; a positive–going pulse coincident with the end of a waveform cycle (and the start of the next).
- pos’n marker:** Position marker; arbitrary waveforms only. Any point(s) on the main waveform may have marker bit(s) set high or low. No output if selected for a standard waveform.
- seq sync:** Sequence sync; a positive–going pulse coincident with the end of a waveform sequence.
- burst done:** A positive–going pulse coincident with the end of the last cycle of a burst.

The default choice is **wfm end** except when the channel is running a sequence in which case it becomes **seq sync**. To set the Trigger Out to anything other than its default it is necessary to change the mode from **auto** to **manual** using the **mode** soft–key.

Trigger Out is an internal signal but, as with the other trigger sources, a positive–edged version is available at the triggered channel’s SYNC OUT with its default source of **trigger** selected.

## Triggered Burst

Triggered Burst mode is turned on with the **triggered** soft–key on the **MODE** screen. The **setup...** soft–key on this screen accesses the **TRIGGER/GATE SETUP** screen on which the burst count and start phase are set. The other trigger parameters are set on the **TRIGGER IN** setup screen called by pressing the TRIG IN key.

```
◆source: int force ◆
◆slope: positive
◆level: +1.4 V
◆period: 1.00ms
```

## Trigger Source

The trigger source can be selected with the **source** soft–key on the **TRIGGER IN** setup screen to be **int** , **ext** , **man** or either of the adjacent channels.

With **int** selected the internal trigger generator is used to initiate a burst; this generator is set up as described in the previous section.

With **ext** selected the specified edge of the signal at TRIG IN is used to initiate a burst.

---

With **chan x** selected the Trigger Out signal from adjacent channel x is used to initiate a burst; the source of the Trigger Out signal on that channel x is set up as described in the previous section.

With **man** selected as the source only pressing the MAN TRIG key or a remote command can be used to initiate a burst. In multi channel instruments, pressing MAN TRIG will trigger **all** those channels for which **man** has been selected as the source.

## Trigger Edge

The **slope** soft-key is used to select the edge ( **positive** or **negative** ) of the external trigger signal that is used to initiate a burst. The default setting of **positive** should be used for triggering by the Internal Trigger Generator or an adjacent channel's Trigger Out. Note that the **trigger** signal from SYNC OUT, used for synchronising the display of a triggered burst on an oscilloscope for example, is always positive-going at the start of the burst.

## Burst Count

The number of complete cycles in each burst following the trigger is set from the **TRIGGER/GATE SETUP** screen called by pressing **setup** on the **MODE** screen.

```
TRIGGER/GATE SETUP:
◆burst cnt: 0000001
◇phase:   +000.0°
(actual: +000.0°)
```

The required count can be set by pressing the **burst cnt** soft-key followed by direct entries from the keyboard or by using the rotary control. The maximum number of waveform cycles that can be counted is 1048575 ( $2^{20}-1$ ).

## Start Phase

The start phase, i.e. the point on the waveform cycle at which the burst starts, can be selected by pressing the **phase** soft-key followed by direct entries from the keyboard or by using the rotary control. Since the waveform cycle is always completed at the end of the burst the start phase is also the stop phase.

The phase can be set with a precision of  $0.1^\circ$  but the actual resolution is limited with some waveforms and at certain waveform frequencies as detailed below. To indicate when this is the case the actual phase is shown in brackets as a non-editable field below the programmed value.

To achieve start phase precision all waveforms are run in Clock Synthesis mode, i.e. as if they were arbitrary waveforms, when Triggered Burst is specified; this limits actual frequency resolution to 8 digits for all waveforms although the normally DDS generated waveforms are still entered with 10-digit precision. Sine/cosine/haversine/etc. waveforms are created as if they were arbitrary waveforms with the first point of the waveform exactly at the start phase; each time the phase or frequency is changed the waveform is recalculated which can cause a slight lag if these parameters are being changed quickly with the rotary knob.

The phase resolution of true arbitrary waveforms is limited by the waveform length since the maximum resolution is 1 clock; thus waveforms with a length  $>3600$  points will have a resolution of  $0.1^\circ$  but below this number of points the maximum resolution becomes  $360^\circ \div$  number of points.

---

Square waves, pulse, pulse trains and sequences have no start phase adjustment; phase is fixed at 0°. A summary of start phase capabilities in Triggered Burst mode is shown in the table below:

Waveform	Max Wfm Freq	Phase Control Range & Resolution
Sine, cosine, haversine, havercosine	2.5MHz	± 360°, 0.1°
Square	2.5MHz	0° only
Triangle	500kHz	± 360°, 0.1°
Ramp	500kHz	± 360°, 0.1°
Sin(x)/x	500kHz	± 360°, 0.1°
Pulse & Pulse Train	25MHz	0° only
Arbitrary	100MS/s clock	± 360°, 360 ÷ length or 0.1°
Sequence	100MS/s clock	0° only

### Manual Initialisation of Inter-channel Triggering

If a multi-channel instrument is set up such that all channels are triggered by an adjacent one it is possible to have a stable condition where all channels are waiting for a trigger and the sequence of triggered bursts never starts. To overcome this problem any channel can be triggered manually and independently using the **force** soft-key on that channel's **TRIGGER IN** screen; select the channel to start the sequence with the appropriate SETUP key, select the **TRIGGER IN** screen with the TRIG IN key and press the **force** soft-key.

### Gated Mode

Gated mode is turned on with the **gated** soft-key on the **MODE** screen. The **setup...** soft-key on this screen accesses the **TRIGGER/GATE SETUP** screen on which the start phase is set. The other parameters associated with Gated are set on the **TRIGGER IN** setup screen called by pressing the TRIG IN key.

```
◆source: int force◆  
◆slope: positive  
◆level: +1.4 V  
◆period: 1.00ms
```

### Gate Source

The gate signal source can be selected with the **source** soft-key on the **TRIGGER IN** setup screen to be **int**, **ext**, or either of the adjacent channels.

With **int** selected the internal trigger generator is used to gate the waveform; the duration of the gate is half the generator period, see Internal Trigger Generator section.

With **ext** selected the gate duration is from the threshold level set on the specified edge of the signal at TRIG IN until the same level on the opposite edge; the threshold and edge are set using the **level** and **slope** soft-keys respectively.

With **chan x** selected the Trigger Out signal from the adjacent channel x is used to gate the waveform; the source of the Trigger Out signal on that channel x is set up as described in the previous section.

---

## Gate Polarity

If **slope** on the **TRIGGER IN** setup screen is set to **positive** the gate will open at the threshold on the rising edge and close on the threshold of the falling edge of an external gating signal, i.e. the gate signal is true when the TRIG IN signal is high. If the **slope** is set **negative** the gate signal is true when the TRIG IN signal is low. The default setting of positive should be used for gating with the Internal Trigger Generator or an adjacent channel's Trigger Out.

## Start Phase

Press **setup...** on the **MODE** screen to access the **TRIGGER/GATE SETUP** screen on which the start phase can be set.

```
TRIGGER/GATE SETUP:
◆BURST CNT: 0000001
◇PHASE:    +000.0°
(actual: +000.0°)
```

The start phase, i.e. the point on the waveform cycle at which the gated waveform starts, can be selected by pressing the **phase** soft-key followed by direct entries from the keyboard or by using the rotary control. Since the waveform cycle is always completed at the end of the gated period the start phase is also the stop phase.

The phase can be set with a precision of  $0.1^\circ$  but the actual resolution is limited with some waveforms and at certain waveform frequencies as detailed below. To indicate when this is the case the actual phase is shown in brackets as a non-editable field below the programmed value.

To achieve start phase precision all waveforms are run in Clock Synthesis mode, i.e. as if they were arbitrary waveforms, when Gated mode is specified; this limits frequency resolution to 8 digits for all waveforms although the normally DDS generated waveforms are still entered with 10-digit precision. Sine/cosine/haversine/etc. waveforms are created as if they were arbitrary waveforms with the first point of the waveform exactly at the start phase; each time the phase or frequency is changed the waveform is recalculated which can cause a slight lag if these parameters are being changed quickly with the rotary knob.

The phase resolution of true arbitrary waveforms is limited by the waveform length since the maximum resolution is 1 clock; thus waveforms with a length  $>3600$  points will have a resolution of  $0.1^\circ$  but below this number of points the maximum resolution becomes  $360^\circ \div \text{number of points}$ .

Square waves, pulse, pulse trains and sequences have no start phase adjustment; phase is fixed at  $0^\circ$ . Refer to the table in the Triggered Burst section for a summary of start phase capabilities.

## Sync Out in Triggered Burst and Gated Mode

When Triggered Burst or Gated modes are selected the SYNC OUT source automatically defaults to **trigger**; **trigger** is a positive-edged signal synchronised to the actual trigger used whether internal (from the Internal Trigger Generator or an adjacent channel) or external of either polarity.

Alternatively, SYNC OUT can be set to **burst done** on the **SYNC OUT** setup screen; sync out then provides a signal which is low while the waveform is running and high at all other times.

## General

In Tone mode the output is stepped through a user-defined list of up to 16 frequencies under the control of the signal set by the **source** soft-key on the **TRIGGER IN** setup screen. This signal can be the Internal Trigger Generator, an external trigger input, the front panel MAN TRIG key or a remote command. On multi-channel instruments the control signal can also be the Trigger Out from an adjacent channel.

All standard and arbitrary waveforms can be used in Tone mode with the exception of pulse, pulse-train and sequence. During Tone all waveforms are generated in DDS mode for fast phase-continuous switching between frequencies. For DDS operation all waveforms must be 4096 points in length; this is the natural length for standard waveforms but all arbitrary waveforms are expanded or condensed in software to 4096 points when the Tone list is built. This does not affect the original data.

Because DDS mode is used the frequency range for all waveforms is 1mHz to 40MHz in Tone mode, including triangle, ramp and squarewave which have different limits in continuous operation.

## Tone Frequency

Press the **tone setup...** soft-key on the **MODE** screen, called by pressing the MODE key, to get the **TONE** setup screen:

```
TONE      type: trig◇
◇2.000000 kHz #2
◆3.000000 kHz del◇
◇end of list #4
```

Each frequency in the list can be changed by pressing the appropriate soft-key and entering the new value from the keyboard. The selected frequency can be deleted from the list by pressing the **del** (delete) soft-key. Additional frequencies can be added to the end of the list by selecting **end of list** with the appropriate soft-key and entering the new frequency from the keyboard.

The whole list can be scrolled back and forward through the display using the rotary control.

## Tone Type

The **type** soft-key on the **TONE** setup screen permits three types of tone switching to be specified.

With **type** set to **trig** the frequency changes after each occurrence of the signal edge specified in the **source** and **slope** fields on the **TRIGGER IN** screen but only after completing the last cycle of the current frequency.

With **type** set to **gate** the frequency changes when the signal specified in the **source** field goes to the level specified in the **slope** field on the **TRIGGER IN** screen and continues until the level changes again at which point the current cycle is completed; the output is then gated off until the next occurrence of the gating signal at which time the next frequency in the list is gated on. The difference between triggered and gated tone changes is therefore that in triggered mode the signal changes phase-continuously from one frequency to the next at the waveform zero-crossing point immediately after the trigger signal whereas in gated mode there can be an 'off' period between successive frequencies whilst the gate signal is not true.

With **type** set to **fsk** the frequency changes instantaneously (and phase-continuously) at each occurrence of the signal edge specified in the **source** and **slope** fields on the **TRIGGER IN** screen **without completing the current waveform cycle**; this is true FSK (Frequency Shift Keying) tone switching.

---

The following diagram demonstrates the differences between trigger, gate and FSK tone switching for a list of 2 frequencies switched by a square wave (positive slope specified on TRIGGER IN setup).

The maximum recommended tone frequencies and trigger/gate switching frequencies for the three modes are as follows:

- GATE: Maximum tone frequency 50kHz; maximum switching frequency <lowest tone frequency.
- TRIGGER: Maximum tone frequency 50kHz; maximum switching frequency 1MHz.
- FSK: Maximum tone frequency 1MHz; maximum switching frequency 1MHz.

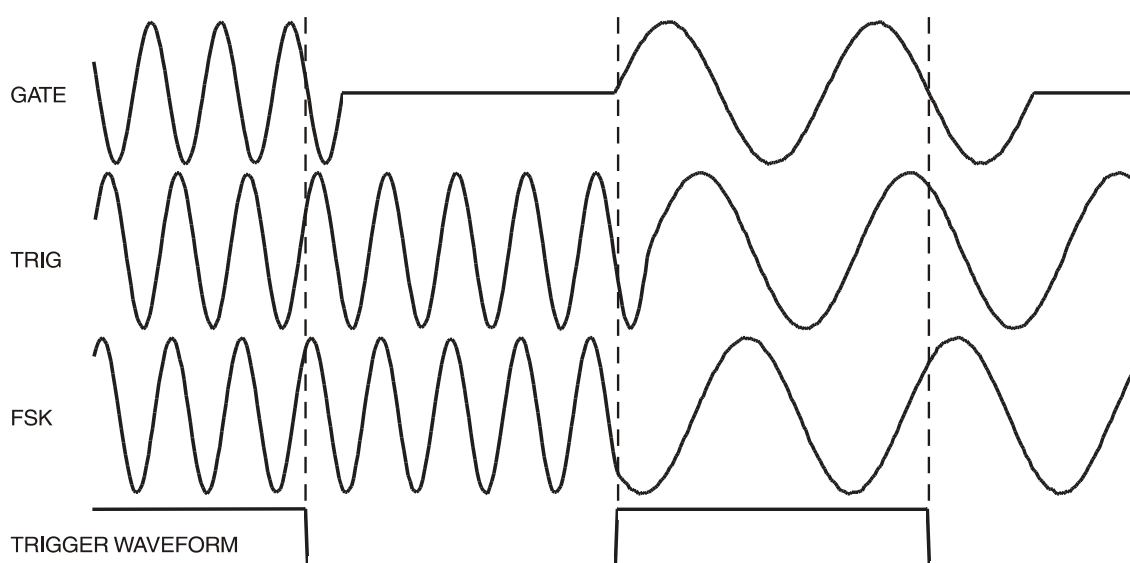

Tone Waveform Types

## Tone Switching Source

The signal which controls the frequency switching is that set by the **source** soft-key on the **TRIGGER IN** setup screen. The **slope** field on the same screen sets the active polarity of that signal; when set to **positive** the rising edge of the trigger signal is active or the high level of the gating signal is true and the reverse is true for a **negative** setting. The signal that can be selected by the **source** soft-key can be the Internal Trigger Generator, an external trigger input, the front panel MAN TRIG key or a remote command and, for multi-channel instruments, Trigger Out of an adjacent channel; a full explanation for each of these can be found in the Triggered Burst and Gate chapter.

## DTMF Testing with Multi-Channel Generator

An important use of Tone mode is DTMF (Dual Tone Multiple Frequency) testing in which 2 channels are set up with equal length lists of different frequencies and are triggered from a common external signal. The outputs are summed together using the internal SUM facility; see SUM chapter. DTMF testing generally uses sinewaves in the frequency range 600Hz to 1.6kHz.

It is also possible to set up DTMF testing using two single channel instrument triggered by a common external signal and summed using the external SUM capability.

## Introduction

Arbitrary (Arb) waveforms are generated by sequentially addressing the RAM containing the waveform data with the arbitrary clock. The frequency of the arb waveform is determined both by the arb clock and the total number of data points in the cycle.

In this instrument an arb waveform can have up to 1048576 horizontal points. The vertical range is –2048 to +2047, corresponding to a maximum peak–peak output of 20 Volts. Up to 500 waveforms can be stored on the memory card and each given a name; the number that can be stored depends on the number of points in each waveform and the size of the memory card.

Arb waveforms can be created using basic front panel editing capabilities (particularly useful for modifying existing standard or arb waveforms) or by using waveform design software that enables the user to create waveforms from mathematical expressions, from combinations of other waveforms, or freehand, see Appendix 4.

## Arb Waveform Terms

The following terms are used in describing arb waveforms:

- *Horizontal Size*. The number of horizontal points is the time component of the waveform. The minimum size is 8 points and the maximum is 1048576 points.
- *Waveform Address*. Each horizontal point on an arb waveform has a unique address. Addresses always start at 0000, thus the end address is always one less than the horizontal size.
- *Arb Frequency and Waveform Frequency*. The arb frequency is the clock rate of the data RAM address counters and has a range of 0.1Hz to 100MHz (internal clock) or DC to 50MHz (external clock) on this instrument. The waveform frequency depends on both the arb frequency and horizontal size. A 1000 point waveform clocked at an arb frequency of 100MHz has a waveform frequency of  $100\text{e}6 \div 1000 = 100\text{kHz}$ .
- *Data Value*. Each point in the waveform has an amplitude value in the range –2048 to +2047.
- *Arb Waveform Amplitude*. When playing arb waveforms the maximum output amplitude will depend on both the range of data values and the output amplitude setting. A waveform that contains data values ranging from –2048 to +2047 will produce a maximum output which is 100% of the programmed peak–to–peak amplitude; if the maximum range of the data values is only –1024 to +1023, for example, the maximum output will only be 50% of the programmed level.

## Arb Waveform Creation and Modification – General Principles

Creating arb waveforms with the instrument alone consists of two main steps:

- Creating a new blank waveform, or a copy of an existing one, and giving it a size and a name
- Modifying that waveform using the various editing capabilities to get exactly the waveform required.

These steps are fully described in the Creating New Waveforms and Modifying Arbitrary Waveforms sections which follow.

Waveform creation using waveform design software also consists of two steps:

- Creating the waveform using the software on a PC.
- Downloading the waveform directly to the memory card (using the USB-connected card reader/writer) and inserting the card into the instrument. Alternatively, the waveform can be downloaded to the generator via the RS232, GPIB or USB interfaces.

This process is described in Appendix 4.

Modification of an arb waveform that is currently running on the instrument is subject to certain constraints; these are mentioned in the appropriate individual sections and warning/error messages will be given if illegal operations are attempted. As a general rule, modification of a current waveform should only be implemented with the generator running in **continuous** mode.



---

## Selecting and Outputting Arbitrary Waveforms

With a memory card plugged in, press the ARB key to see the list of all the arbitrary waveforms held on the card.

```
ARBITRARY WAVEFORMS
◇WFM1          4096
◇WFM2          11000
◇SPIKE100     100000
```

If no card is fitted the display will show the message **Please insert a memory card**. If there are no waveforms on the card the message will be **There are no arb waveforms available**; see next section for creating new waveforms. If the generator is switched on without a card fitted, and the power-on conditions have been set to recall power-down set-up which included an arb waveform, an error message **File (name) not found, load std square** is temporarily displayed and the generator defaults to a squarewave output.

With a card plugged in the rotary knob or cursor keys can be used to scroll the full list backwards and forwards through the display. Select the required waveform by pressing the associated soft-key.

To make it easier to find a particular waveform in a long list it is recommended that the waveforms on the card are first sorted into alphabetical order using the sort facility on the **MEMORY CARD** screen accessed from the **UTILITY** menu, see Memory Card and Other System Operations section.

Note that the last used arb waveform can also be selected to run from the **STANDARD WAVEFORMS** screen, accessed by pressing the STD key, by pressing the **arb** soft-key in the **STANDARD WAVEFORMS** list; this makes it easier to quickly switch between a true standard waveform (e.g. sine) and a particular arb.

## Creating New Waveforms

Pressing the CREATE key calls the **CREATE NEW WAVEFORM** screen.

```
CREATE NEW WAVEFORM
◇create blank...
◇create from copy...
```

### Create Blank Waveform

Pressing the **create blank...** soft-key calls the menu:

```
◆create: "WFM1  "
◇size:  0001024

◇cancel      create◇
```

The top line contains the user-defined waveform name which can be 8 characters long. The instrument allocates a default name of WFM(n) starting at WFM1; the name can be edited by selecting the appropriate character position with the cursor keys and then setting the character with the rotary control which scrolls through all alphanumeric characters in sequence.

Pressing the **size** soft-key permits the waveform length to be entered directly from the keyboard or by using the rotary control and cursor keys; the default size is 1024. The minimum size is 8 and the maximum 1048576; appropriate warnings are given if attempts are made to set a waveform size outside these limits.

This menu can be exited either by pressing the **cancel** soft-key which keeps the name but does not allocate the memory space, or by pressing the **create** soft-key which builds a "blank" waveform and returns the screen to the **ARBITRARY WAVEFORMS** list.

---

## Create Waveform Copy

Pressing the **create from copy...** soft-key calls the following menu:

```
◆create: "WFM1  "  
◇from:  sine  
◇size:  0001024  
◇cancel      create◇
```

The user-defined name and waveform size can be entered after pressing the **create** and **size** soft-keys respectively, exactly as described in the previous section.

The source waveform which is to be copied can be selected by the **from** soft-key; repeated presses of the soft-key, cursor keys or using the rotary control will scroll through the list of all the available waveforms, including any other arbitrary waveforms already created.

The horizontal size of the waveform being copied does not have to be the same as the waveform being created. When the waveform is copied, by pressing the **create** key, the software compresses or expands the source waveform to create the copy. When the source is expanded the copy has additional interpolated points; when the source is compressed, significant waveform data may be lost, particularly from arb waveforms with narrow spikes if the compression ratio is large.

The menu can be exited by pressing the **cancel** soft-key, which keeps the name but does not implement the copy, or by pressing the **create** soft-key, which makes the copy and returns the screen to the **ARBITRARY WAVEFORMS** list.

## Modifying Arbitrary Waveforms

Pressing the **MODIFY** front panel key calls the **MODIFY** screen.

```
◆MODIFY:  WFM1  
◇resize...  rename...◇  
◇delete...  info...◇  
◇edit wfm..
```

This screen gives access to a number of menus which permit the selected waveform to be resized, renamed, edited, etc. The arb waveform to be modified is selected using the rotary control or cursor keys to step through all possible choices; the current selection is displayed on the top line beside **MODIFY**.

## Resize Waveform

Pressing the **resize...** soft-key on the **MODIFY** screen calls the **Resize** screen.

```
Resize:  WFM11  
(old size: 0016000)  
new size: 0001024  
◇cancel      resize◇
```

**Resize** changes the number of points in the waveform; the new size can be larger or smaller than the old size. When the new size is larger, the software adds additional interpolated points. When the size is smaller, points are removed. Reducing the waveform size may cause the waveform to lose significant data.

---

Enter the size required by pressing the **new size** soft-key followed by direct entries from the keyboard or by using the rotary control. Resize is implemented by pressing the **resize** soft-key or aborted by pressing the **cancel** soft-key; both return the display to the **MODIFY** screen. There is no “undo” for resize.

## Rename Waveform

Pressing the **rename...** soft-key on the **MODIFY** screen calls the **Rename** screen:

```
Rename:   WFM1
         as  "WFM2  "
◊cancel      rename◊
```

The new name can be entered below the original by selecting the appropriate character position with the cursor keys and then setting the character with the rotary control which scrolls through all the alphanumeric characters in sequence. The name can be up to 8 characters long.

Return to the **MODIFY** screen by pressing **rename** (which implements the new name) or **cancel**.

## Waveform Info

Pressing the **info...** soft-key on the **MODIFY** screen calls the **info** screen.

```
Info WFM1      exit◊
length:      1024
chan:
seq:
```

The screen gives the name of the waveform, its length and the channels (in multi-channel versions of the generator) and sequences where it is used.

Pressing **exit** returns the display to the **MODIFY** screen.

## Delete Waveform

Pressing the **delete...** soft-key displays a request for confirmation that the selected waveform is to be deleted from the memory card.

```
Delete waveform
      "WFM1  "
      ?
◊cancel      delete◊
```

Confirm deletion by pressing the **delete** soft-key which will return the display to the **MODIFY** screen with the next arb waveform automatically selected; **cancel** aborts the deletion.

## Edit Waveform

Pressing the **edit wfm...** soft-key calls the **EDIT FUNCTIONS** menu:

```
EDIT FUNCTIONS:
◊point edit...
◊line draw...
◊wave insert...
```

---

From this menu can be selected functions which permit the waveform to be edited point-by-point (point edit), by drawing lines between two points (line draw) or by inserting all or part of an existing waveform into the waveform being edited (wave insert). In addition, sections of the waveform can be selected and their peak-to-peak level changed using wave amplitude, or baseline changed using wave offset. Sections of the waveform can be copied into itself (block copy) and position markers for use at Sync Out can also be defined.

Pressing the **exit** soft-key on any of these edit screens will return the display to the **EDIT FUNCTIONS** menu.

### Point Edit

Press the **point edit...** soft-key to call the **POINT EDIT** screen:

```
POINT EDIT  WFM1
  (addrs , value)
◆ (0000512, +0500)◆
◆exit      next point◆
```

To modify a point, press the **addr<sub>s</sub>** soft-key and enter the address directly from the keyboard or by using the rotary control; the current data value will be displayed to the right of the address. To change the value press **value** and enter the new value directly from keyboard or by using the rotary control. Changing the data value automatically updates the waveform.

Pressing the **next point** soft-key automatically advances the address by one point; alternatively press **addr<sub>s</sub>** to re-select address and permit entries from the keyboard or by rotary control.

### Line Edit

Press the **line draw...** soft-key to call the **LINE** screen:

```
LINE( addrs ,value)
◆frm(0000512,+0000)◆
◆to (0000750,+0412)◆
◆exit      draw line◆
```

The display shows a **frm** (from) and **to** address which will be the points between which a straight line will be created when the **draw line** soft-key is pressed. The default **frm** address is the first point on the waveform or the point most recently edited if point edit has been used. Set the "from" address and value by pressing the appropriate soft-key and making an entry direct from the keyboard or by using the rotary control; repeat for the "to" address and value.

The line will be drawn between the two selected points when the **draw line** soft-key is pressed.

### Wave Insert

Pressing **wave insert...** calls the wave insert screen:

```
◆WFM1      → WFM2
◆000000 strt 0000400◆
◆0000512 stop 0100000◆
◆exit      insert◆
```

Wave Insert places waveforms between programmable start and stop points. Both standard and arbitrary waveforms can be inserted in the new waveform, with the exception of pulse, pulse-train and sequence.

---

A section of an arbitrary waveform can be inserted, as defined by the left-hand **strt** (start) and **stop** addresses, e.g. 0000000 and 0000512 of **WFM1** on the screen above; these addresses default to the start and stop of the whole waveform but can be reset to define any section of the waveform. Change the addresses by pressing the appropriate soft-key and making entries from the keyboard or by rotary control. The destination of the selected section of the source waveform in the new waveform is defined by the right-hand **strt** (start) and **stop** addresses. Change the addresses by pressing the appropriate soft-key and making entries from the keyboard or by rotary control.

The insert is actioned by pressing the **insert** soft-key. If there is a size difference between the two sections of waveform then the software will expand or compress the source to fit the new waveform. Compressing the waveform may lose some significant data.

To insert sections of the current waveform within itself see Block Copy.

## Block Copy

Pressing **block copy...** calls the **BLOCK COPY** screen:

```
BLOCK COPY: WFM42
◆start:0000400
◇ stop: 0001000 copy ◇
◇ dest: 0000000 exit ◇
```

Block copy allows a section of the current waveform to be inserted within itself. The block to be inserted is defined by the **start** and **stop** addresses. Change the addresses by pressing the appropriate soft-key and making entries from the keyboard or by rotary control.

The destination address for the start of the section is set by pressing the **dest** soft-key and entering the address.

Press **copy** to implement the copy. During the 2-stage Block Copy process the screen displays the message **processing file - please wait** with a progress bar. During the first stage the block to be copied is created as a temporary file with the same name as the main file but with a **\$\$\$** extension; during the second stage the appropriate section of the original file is overwritten and the temporary file is deleted.

Note that if there are not enough waveform points between the destination address and end of waveform to accommodate the copied section, the waveform being copied will simply be truncated. Once copied there is no undo and the original waveform cannot be recovered.

Block copy edit operates on the version of the waveform in the channel currently selected by the channel **SETUP** keys; the effect of the edit can be seen by selecting the waveform to run on that channel. When the block copy is as required it can be saved by pressing the **save** soft-key; the action of saving modifies the waveform in the backup memory and then any other copies of the waveform in other channel memories. Once saved the original waveform cannot be recovered.

Pressing **exit** returns to the **EDIT FUNCTIONS** screen without change.

## Waveform Amplitude

Pressing the **wave amplitude** soft-key initiates the creation of a temporary copy of the waveform to be edited and calls the **AMPLITUDE** screen:

```
AMPLITUDE: 001.00 ◆
◇0000000 to 0000123 ◇
◇undo      set ampl ◇
◇save & exit  save ◇
```

---

The waveform amplitude can be changed on a section of the waveform defined by the start and stop addresses. Set the addresses by pressing the appropriate soft-key and making entries directly from the keyboard or by rotary control.

The data values over the specified section of the waveform can be multiplied by a factor of between 0.01 and 100.0 by making entries in the **AMPLITUDE** field. Press the appropriate soft-key and make entries direct from the keyboard or by using the rotary control; the amplitude changes on completion of the entry. Note that entries >1.0 will cause clipping if the waveform already uses the full -2048 to +2047 data value range; the result is, however, still treated as a valid waveform. The original waveform can be restored by pressing the **undo** soft-key.

Amplitude edit operates on the version of the waveform in the channel currently selected by the channel SETUP keys; the effect of the edit can be seen by selecting the waveform to run on that channel. When the amplitude has been modified as required the new waveform can be saved by pressing the **save** key; once saved the original waveform cannot be recovered.

Pressing **save & exit** returns to the **EDIT FUNCTIONS** screen after the save has been implemented. To exit the **AMPLITUDE** edit without saving changes, press **undo** then **save & exit**.

## Waveform Offset

Pressing the **wave offset** soft-key initiates the creation of a temporary copy of the waveform to be edited and calls the **WAVE OFFSET** screen.

```
WAVE OFFSET:  +0000 ♦
◊0000000 to 0000123 ◊
◊undo      set offset ◊
◊save & exit  save ◊
```

The waveform offset can be changed on a section of the waveform defined by the start and stop addresses. Set the addresses by pressing the appropriate soft-key and making entries directly from the keyboard or by rotary control.

The data values over the specified section of the waveform are offset by the value entered in the **WAVE OFFSET** field. Press the appropriate soft-key and make entries direct from the keyboard or by using rotary control. Entries in the range -4096 to +4095 will be accepted; this permits, in the extreme, waveform sections with values at the -2048 limit to be offset to the opposite limit of +2047. Warnings are given when the offset causes clipping but the entry is still accepted. The original waveform can be restored by pressing the **undo** soft-key.

Offset edit operates on the version of the waveform in the channel currently selected by the channel SETUP keys; the effect of the edit can be seen by selecting the waveform to run on that channel. When the offset has been modified as required the new waveform can be saved by pressing the **save** key; once saved the original waveform cannot be recovered.

Pressing **save & exit** returns to the **EDIT FUNCTIONS** screen after the save has been implemented. To exit the **WAVE OFFSET** edit without saving changes, press **undo** then **save & exit**.

## Wave Invert

Pressing the **wave invert** soft-key calls the **INVERT** screen:

```
INVERT:      WFM1
♦start adrs: 0000512
◊stop adrs:  0000750
◊exit        invert ◊
```

---

The waveform can be inverted on a section of the waveform defined by the **start** and **stop** addresses. Set the addresses by pressing the appropriate soft-key and making entries directly from the keyboard or by rotary control.

The data values over the specified section of the waveform are inverted about 0000 each time the **invert** soft-key is pressed.

Press **exit** to return to the **EDIT FUNCTIONS** screen.

## Position Markers

Pressing the **position markers...** soft-key calls the **POSITION MARKER EDIT** screen:

```
POSITION MARKER EDIT
▲ads: 0000000 <0>◊
◊patterns...
◊exit      clear all◊
```

Position markers are output from SYNC OUT when the source (**src**) is set to **pos'n marker** on the **SYNC OUTPUT SETUP** screen.

Position markers can be set at any or all of the addresses of a waveform either individually, using the **ads** (address) soft-key, or as a pattern, using the **patterns...** menu.

A marker can be set directly at an address by pressing the **ads** soft-key followed by a keyboard entry; pressing the right-hand soft-key on the **ads** line then toggles the marker setting between <1> and <0> as shown in the arrowed brackets. The address can be changed by incrementing with the **ads** key, by using the rotary control, or by further keyboard entries; marker settings are changed at each new address with the right-hand soft-key. Markers show immediately they are changed.

Alternatively, markers can be input as patterns by using the **patterns...** sub-menu.

```
PATTERN: 00000000...◆
◊start: 0000000
◊stop: 0001023
◊exit: do pattern◊
```

The start and stop addresses of the markers within the waveform are set using the **start** and **stop** soft-keys respectively followed by a direct keyboard entry or by rotary control.

The pattern itself is set in the top line of the display; press the soft-key to the right of **PATTERN:** and enter the sequence of 1s and 0s using 1 and 0 from the keyboard (which auto-increments to the next character) or with the rotary control (using the cursor keys to move the edit cursor along the pattern). The pattern consists of 16 values; if the cursor keys are used to skip over some character positions these will automatically be filled with the value of the last one specified to the left. The pattern is entered repeatedly across the whole range defined by the start and stop addresses when the **do pattern** soft-key is pressed; pressing **exit** returns to **POSITION MARKER EDIT** screen without implementing the pattern.

Pressing the **clear all** soft-key displays a request for confirmation that all markers should be cleared from the waveform. Pressing **clear** cancels all the markers and returns the display to **POSITION MARKER EDIT**; pressing **cancel** aborts the clear.

---

## Arbitrary Waveform Sequence

Up to 1024 arbitrary waveforms may be linked in a sequence provided that the total number of points of all the waveforms in the sequence does not exceed 1048576. Each waveform can have a loop count of up to 32768 and the whole sequence can run continuously or be looped up to 1048575 times using the Triggered Burst mode.

Pressing the SEQUENCE key calls the initial **SEQUENCE** screen:

```
SEQUENCE  segs=    1
◊sequence setup...

◆stop                run◊
```

A previously defined sequence can be run and stopped from this screen using the **run** and **stop** soft-keys; sequence can also be switched on from the **STANDARD WAVEFORMS** screen with the **sequence** soft-key. The **segs=** field shows the number of segments in the sequence; there is always at least 1 segment.

### Sequence Set-up

Pressing the **sequence setup...** soft-key on the **SEQUENCE** screen (or the **setup...** soft-key next to **sequence** on the **STANDARD WAVEFORMS** screen) calls the sequence set up screen:

```
◆seg: 0002          off◊
◆wfm WFM3
◊step on: count
◊cnt: 00001        done◊
```

Repeated presses of the **seg** soft-key steps the display through the set-ups of each of the 1024 segments of the sequence. With the exception of segment 1 which is always on (and therefore has no on-off soft-key) the segment set-ups are identical in format. When segment 1 is displayed the **segs=** field shows the total number of segments in the current sequence.

The segment to be set-up is selected with the **seg** soft-key; the segments can be selected in sequence with repeated presses of the soft-key, by using the rotary control or by numeric entry. Once the segment to be edited has been set the waveform for that segment is selected with the **wfm** (waveform) soft-key; the list of all arbitrary waveforms already created is stepped through with repeated presses of the **wfm** soft-key or by using the rotary control.

The criterion for stepping between waveform segments is set by the **step on** soft-key. The default setting is **step on: count** which means that the waveform will step on to the next segment after the number of waveform cycles specified in the **cnt** (count) field; up to 32768 cycles can be set with **cnt** selected, using direct keyboard entries or by rotary control.

Alternatively, the step on criteria can be set to **trig edge** or **trig level** in the step on field; trigger edge or trigger level can be mixed with count (i.e. some segments can step on count, others on the specified trigger condition) but trigger edge cannot be mixed with trigger level in the same sequence.

If **trig edge** is selected the sequence starts running at the first waveform segment when sequence is set to **run** and steps to the following segments in turn at each subsequent trigger. The trigger source can be any of the settings selected on the **TRIGGER IN** setup screen (called by the TRIG IN key); these are described fully in the Triggered Burst and Gate section. At each trigger the current waveform cycle plus one further whole cycle are completed before the waveform of the next segment is started.



---

If **trig level** is selected the sequence runs continuously through each segment in turn (1 cycle per segment) while the trigger level is true. When the trigger level goes false the waveform currently selected runs continuously until the level goes true again at which point the sequence runs continuously through each segment in turn again. The trigger level source can be any of the settings selected on the **TRIGGER IN** setup screen with the exception of the MAN TRIG key which can only produce an edge, not a level, when pressed.

Providing the **step on:** field is set to **count** for all segments the waveform sequence can also be run in Gated and Triggered Burst modes in the same way as simple waveforms; refer to the Triggered Burst and Gated section for full details.

The individual segments of the sequence can be turned on or off with the **on-off** soft-key. Note that turning a segment off will automatically set all subsequent segments off; turning a segment on will also turn on any others between segment 1 and itself that were previously off. Segment 1 is always on.

When the whole sequence is defined the set-up is constructed by pressing the **done** soft-key which returns the display to the initial **SEQUENCE** screen. The sequence can be run and stopped from this screen with the **run** and **stop** soft-keys respectively.

## Frequency and Amplitude Control with Arbitrary Waveforms

Frequency and Amplitude control work in essentially the same way as for standard waveforms with the following differences.

### Frequency

Pressing the FREQUENCY key with an arbitrary waveform selected calls the **ARBITRARY FREQUENCY** screen:

```
◇ ARB FREQUENCY: int
    100.00000 MHz
◆sample    waveform◇
◆freq      period◇
```

Arbitrary mode uses Clock Synthesis generation, see Principles of Operation section, which has a setting resolution of only 8 digits. However, the clock can also be provided from an external source via the rear panel ARB CLOCK IN/OUT socket or, on multi-channel instruments, the System Clock. The clock source switches between **internal** and **external** clock with alternate presses of the **ARB FREQUENCY** soft-key. When external clock is selected the **ARB FREQUENCY** screen changes to:

```
◇ ARB FREQUENCY: ext
    source: ext arb clk
```

on a single channel instrument or:

```
◇ ARB FREQUENCY: ext
◆source: ext arb clk
◇freq: 10.000000kHz
```

on a multi-channel instrument. It is then possible to select the source to be either an external signal on the ARB CLOCK IN/OUT socket or the Internal System Clock; see the Reference Clock IN/OUT and System Clock Setting sections of System Operations on the Utility Menu, for how to use and set the frequency of the System Clock.

---

Note that SEQUENCE and the 'standard' waveforms of Pulse & Pulse-train also operate in Clock Synthesis mode and consequently can also be set to external clock on the appropriate FREQUENCY menus, see relevant sections for further details.

Having selected external clock the arbitrary waveform will continue to run from the internal clock until the instrument receives the first rising edge of the external clock; at that point the hardware switches over to the external source.

The following applies only to **internal** clock selection.

Frequency can be set in terms of frequency or period as for standard waveforms by pressing the **freq** or **period** soft-key respectively. Additionally, for arbitrary waveforms, frequency/period can be set in terms of the sample clock frequency, by pressing the **sample** soft-key, or in terms of the waveform frequency, by pressing the **waveform** soft-key. The relationship between them is

$$\text{waveform frequency} = \text{sample frequency} \div \text{waveform size.}$$

Frequency/period entries are made direct from the keyboard or by using the rotary control in the usual way. Pressing the FREQUENCY key with Sequence running calls the **SEQ FREQUENCY** screen:

```
◇ SEQ FREQUENCY: int
    100.00000 MHz
◆freq          period◇
```

With **internal** clock selected (the default), frequency/period can now **only** be set in terms of the clock frequency. Frequency/period entries are made direct from the keyboard or by using the rotary control in the usual way.

With **external** clock selected using the **SEQ FREQUENCY** soft-key the sequence can be clocked using an external source connected to the rear panel ARB CLOCK IN/OUT socket or the System Clock on a multi-channel instrument.

## Amplitude

Pressing the AMPLitude key with an arbitrary waveform selected calls the **AMPLITUDE** screen.

```
AMPLITUDE:
    +20.0 Vpp
◆Vpp
    load:hiz◇
```

This differs from the **AMPLITUDE** screen for standard waveforms in that amplitude can now only be entered in volts peak-to-peak.

Note that the peak-to-peak amplitude set will only actually be output if the arbitrary waveform has addresses with values which reach -2048 and +2047; if the maximum value range is -1024 to +1023 for example then the maximum peak-to-peak voltage will only be 10Vpp for the instrument set to 20Vpp.

## Sync Out Settings with Arbitrary Waveforms

The default setting for Sync Out when arbitrary waveforms are selected is **waveform sync**; this is a pulse that starts coincident with the first point of the waveform and is a few points wide.

If a waveform sequence has been selected then Sync Out defaults to **sequence sync**; this is a waveform which goes low during the last cycle of the last waveform in a sequence and is high at all other times. When sequence is used in Triggered Burst mode the burst count is a count of the number of complete sequences.

---

## Waveform Hold in Arbitrary Mode

Arbitrary waveforms can be paused and restarted on any channel by using the front panel MAN HOLD key or a signal applied to the rear panel HOLD IN socket.

On multi-channel instruments the channels which are to be held by the MAN HOLD key or HOLD IN socket must first be enabled using the **ARB HOLD INPUT** screen, accessed by pressing the HOLD key.

```
ARB HOLD INPUT:
status: no hold
mode: disabled
```

Each channel is selected in turn using the channel SETUP keys and set using the **mode** soft-key; the mode changes between **disabled** and **enabled** with alternate key presses.

Pressing the front panel MAN HOLD key stops the waveform at the current level on all enabled channels; pressing MAN HOLD a second time restarts the waveform from that level. If the **ARB HOLD INPUT** screen is currently selected the **status** field will change from **no hold** to **manual hold** while the waveform is paused.

A logic low or switch closure at the rear panel HOLD IN socket also stops the waveform at the current level on all enabled channels; a logic high or switch opening restarts the waveform from that level. If the **ARB HOLD INPUT** screen is currently selected the **status** field will change from **no hold** to **ext. hold** while the waveform is paused.

## Output Filter Setting

The output filter type is automatically chosen by the software to give the best signal quality for the selected waveform. The choice can, however, be overridden by the user and this is most probably a requirement with arbitrary waveforms.

To change the filter, press the FILTER key to call the **FILTER SETUP** screen.

```
FILTER SETUP
mode: auto
type: 40MHz elliptic
```

The default **mode** is **auto** which means that the software selects the most appropriate filter. With the setting on **auto** the **type** can be changed manually but the choice will revert to the automatic selection as soon as any relevant parameter is changed. To override the automatic choice press the **mode** soft-key to select **manual**.

The three filter choices, which are either automatically selected or set manually with the **type** soft-key, are as follows:

- *40MHz elliptic*: The automatic choice for sine, cosine, haversine, havercosine, sinx/x and triangle. Would be the better choice for arb waveforms with an essentially sinusoidal content.
- *20MHz Bessel*: The automatic choice for positive and negative ramps, arb and sequence.
- *No filter*: The automatic choice for squarewave, pulse and pulse-trains. May be the better choice for arb waveforms with an essentially rectangular content.

Pulse and pulse-trains are both selected and set-up from independent menus on the **STANDARD WAVEFORMS** screen called by pressing the STD key. Pulse and pulse-trains have similar timing set-ups and considerations but pulses are only unipolar, with a maximum amplitude of 10Vpp, whereas pulse-trains can be bipolar, with a maximum peak-to-peak of 20Vpp.

### Pulse Set-up

Pulse waveforms are turned on with the **pulse** soft-key on the **STANDARD WAVEFORMS** screen; pressing the **setup...** soft-key beside **pulse** calls the first of the pulse set-up screens:

```
Enter pulse period:
100.00000 us
10000pts*10.00000ns
◊exit          next ◊
```

The third line of the screen indicates how the waveform will be constructed; in this case it will be 10000 points played back at a clock period of 10.00000ns to give a period of  $10000 \times 10^{-9} = 100\mu\text{s}$ . These values will change as the period is varied. The clock period will determine the resolution available for setting the delay and width as discussed below.

The pulse period can be set between 40.00000ns and 100.00000s, with 8-digit resolution, by direct entries from the keyboard or by using the rotary control. Pressing the **next** soft-key calls the pulse width screen:

```
Enter pulse width:
program 50.000000 us
actual  50.000000 us
◊exit          next ◊
```

The width can be entered directly from the keyboard or by using the rotary control. Any value in the range 10.00000ns to 99.999999s can be programmed but the **actual** value may differ because of the considerations discussed below; for this reason the **actual** pulse width is shown (in brackets) below the **program** width.

Pressing the **next** soft-key calls the pulse delay screen:

```
Enter pulse delay:
program+0.000000 ns
actual +0.000000 ns
◊exit          done ◊
```

This is very similar to the pulse width screen and, again, the **actual** delay is shown below the **program** delay. The delay value that can be entered must be in the range  $\pm$  (pulse period  $-1$  point); positive values delay the pulse output with respect to waveform sync from SYNC OUT; negative values cause the pulse to be output before the waveform sync. Pressing the **done** soft-key on this screen returns the display to the **STANDARD WAVEFORMS** screen.

The means by which pulse period is set-up in the hardware requires an understanding because it affects the setting resolution of both pulse width and delay. Pulse is actually a particular form of arbitrary waveform made up of between 4 and 100,000 points; each point has a minimum time of 10.000000ns corresponding to the fastest clock frequency of 100MHz.

At short pulse periods, i.e. only a few points in the waveform, the period setting resolution is, however, much better than 10·000000ns because the time-per-point is adjusted as well as the number of points; since the pulse width and delay are also defined in terms of the same point time, varying the time-per-point affects their resolution. For example, if the period is set to 200·00000ns, the minimum pulse width, when set to 10·000000ns, will actually be 10·000000ns; 20 points at 10·000000ns each exactly define the 200·00000ns period. However, if the period is set to 199·00000ns, 20 points at the minimum point time of 10·000000ns will be too long so 19 points are used and the point time is adjusted to 10·473684ns (199·0÷19); 10·473654ns is now the increment size used when changing the pulse width and delay.

For periods above 1ms the maximum number of points in the waveform (100,000) becomes the factor determining pulse width and delay resolution. For example, with the period set to 100ms, the smallest pulse width and delay increment is 1µs (100ms÷100,000). This may appear to cause significant “errors” at extreme settings (e.g. setting 10ns in the above example will still give an actual width of 1µs) but in practical terms a 1 in 100,000 resolution (0·001%) is quite acceptable.

Pulse period can be adjusted irrespective of the pulse width and delay setting (e.g. can be set smaller than the programmed pulse width) because, unlike a conventional pulse generator, pulse width and delay are adjusted **proportionally** as the period is changed. For example, if, from the default pulse settings of 100µs period/50µs width, the period is changed to 60µs the pulse width **actual** changes to 30µs even though the **program** width is still 50µs; to get a 50µs width with the period at 60µs the width must be re-entered as 50µs after the period has been changed. Period can also be changed from the **PULSE PERIOD** screen called by pressing the **FREQ** key with Pulse mode selected.

```

◇PULSE PERIOD: int
    100·00000    us
◇freq          period◇
  
```

The new setting can be entered either as a period in the way already described or as a frequency by first pressing the **freq** soft-key. However, changing the period/frequency from this screen is slightly different from changing period on the **pulse setup** screen. When changing from this screen the number of points in the waveform is never changed (just as with a true arb) which means that the shortest period/highest frequency that can be set is number of waveform points x10·00ns. To achieve faster frequencies (up to the specification limit) the period must be changed from the pulse set-up screen; changing the frequency from the pulse set-up screen causes the number of points to be reduced as the period is reduced (for periods <1ms).

Because Pulse waveforms are actually a particular form of arb and use clock Synthesis mode, Pulse mode can also be operated with an external clock connected to the rear panel ARB CLOCK IN/OUT socket or the System Clock on multi-channel instruments. To select external clock mode press the **PULSE PERIOD** soft-key on the **PULSE PERIOD** screen (or the **PULSE FREQ** soft-key on the **PULSE FREQ** screen) to change from **internal** to **external** clock. The screen changes to, for example:

```

◇PULSE PERIOD: ext
    source: ext arb clk
  
```

on a single channel instrument or:

```

◇PULSE PERIOD: ext
    ◆source: ext arb clk
    ◇freq: 10·000000kHz
  
```

---

on a multi-channel instrument. It is then possible to select the source to be either an external signal on the ARB CLOCK IN/OUT socket or the Internal System Clock; see the Reference Clock IN/OUT and System Clock Setting sections of System Operations on the Utility Menu, for how to use and set the frequency of the System Clock.

Note that the Pulse waveform will continue to run from the internal clock until the instrument receives the first rising edge of the external clock; at that point the hardware switches over to the external source. In external clock mode the period of the Pulse waveform is determined by the number of points in the waveform x the period of the external clock. The external clock period is determined by the user; the number of points in the Pulse waveform can be found, **before selecting external clock**, by pressing the **set-up** soft-key beside **pulse** on the **STANDARD WAVEFORMS** screen.

## Pulse-train Setup

Pulse-trains are turned on with the **pulse-train** soft-key on the **STANDARD WAVEFORMS** screen; pressing the **setup...** soft-key beside **pulse-train** calls the first of the setup screens:

```
Enter no of pulses
in train (1-10):
      2
◇done      next◇
```

The number of screens used for the setup depends on the number of pulses in the pulse-train. The first three screens define the parameters that apply to the whole pattern (number of pulses, overall pulse-train period and baseline voltage); subsequent screens define the pulse level, width and delay for each pulse in turn (3 screens for pulse 1, then 3 screens for pulse 2, etc.). Pressing **next** on any screen calls the next setup screen, finally returning the display to the **STANDARD WAVEFORMS** screen from which pulse-train can be turned on and off; pressing **done** returns the display directly to the **STANDARD WAVEFORMS** screen from any setup screen. The pulse-train is built only after **next** is pressed after the last parameter setup or whenever **done** is pressed, assuming a change has been made. The first screen, shown above, sets the number of pulses (1–10) in the pattern; enter the number of pulses directly from the keyboard or by using the rotary control.

Pressing **next** calls the pulse train period screen:

```
pulse train period:
      100.00000us
      10000pt*10.00000ns
◇done      next◇
```

The third line of the screen indicates how the waveform will be constructed; in this case it will be 10000 points played back at a clock period of 10.000000ns to give a period of  $10000 \times 10^{-9} = 100\mu\text{s}$ . These values will change as the period is varied. The clock period will determine the resolution available for setting the delay and width as discussed below.

The period can be set, with 8-digit resolution, from 10.000000ns to 100s by direct keyboard entries or by using the rotary control.

Pressing **next** calls the baseline voltage screen, the last of the general setup screens:

```
Enter the baseline
voltage:
+0.000 V
◇done          next◇
```

The baseline is the signal level between the end of one pulse and the start of the next, i.e. it is the level all pulses start and finish at. The baseline can be set between  $-5.0\text{V}$  and  $+5.0\text{V}$  by direct keyboard entries or by using the rotary control. Note that the **actual** baseline level at the output will only be as set in this field if the output amplitude is set to maximum (10Vpp into  $50\Omega$ ) on the AMPLITUDE screen and terminated in  $50\Omega$ . If the amplitude was set to 5Vpp into  $50\Omega$  then the actual baseline range would be  $-2.5\text{V}$  to  $+2.5\text{V}$  for set values of  $-5.0$  to  $+5.0\text{V}$ , i.e. the amplitude control “scales” the baseline setting. The actual output levels are doubled when the output is unterminated.

Pressing **next** on this screen calls the first of 3 screens for the first pulse in the pattern:

```
◇Pulse 1 level
◆          +5.000 V
◇done          next◇
```

The pulse level can be set on this screen between  $-5.0\text{V}$  and  $+5.0\text{V}$  by direct keyboard entries or by using the rotary control. As with the baseline level described above the set pulse levels are only output if the amplitude setting is set to maximum (10Vpp into  $50\Omega$ ) on the AMPLITUDE screen and terminated in  $50\Omega$ . Adjusting the amplitude “scales” both the peak pulse levels and baseline together, thus keeping the pulse shape in proportion as the amplitude is changed, exactly as for arb waveforms. Actual output levels are doubled when the output is unterminated.

Note that by pressing the **Pulse** soft-key on this (and subsequent screens) the pulse to be edited can be directly set from the keyboard or by using the rotary control; this is useful in directly accessing a particular pulse in a long pulse train instead of having to step through the whole sequence.

Pressing **next** calls the pulse width screen for the first pulse:

```
◇Pulse 1 width
◆program 25.000000us
  actual  25.000000us
◇done          next◇
```

The width can be entered directly from the keyboard or by using the rotary control. Any value in the range 10.000000ns to 99.999999s can be programmed but the **actual** value may differ; for this reason the **actual** pulse width is shown below the **program** width. The variation between **program** and **actual** will only really be noticeable for very short pulse-train periods (only a few points in the pulse-train) and very long periods (each of the 100,000 points has a long dwell time) for exactly the same reasons as described in the Pulse Setup section; refer to that section for a detailed explanation.

Pressing **next** calls the pulse delay screen for the first pulse:

```
◇Pulse 1 delay
◆program+0.000000ns
  actual +0.000000ns
◇done          next◇
```

---

The pulse delay is entered in the same way as pulse width and, again, the **actual** delay is shown below the **program** delay for the same reasons. The delay value that can be entered must be in the range  $\pm$  (pulse-train period  $-1$  point); positive values delay the pulse with respect to waveform sync from SYNC OUT; negative values cause the pulse to be output before the waveform sync.

Pressing **next** on this screen calls the first of the 3 screens for setting the parameters of Pulse 2, and so on through all the pulses in the pulse-train. In this way all parameters of all pulses are set. The pulse-train is built when **next** is pressed on the last screen of the last pulse or if **done** is pressed on any screen.

Care must be taken that the set widths and delays of the individual pulses are compatible with each other and the overall pulse-train period, i.e. delays must not be such that pulses overlap each other and delays + widths must not exceed the pulse-train period; unpredictable results will occur if these rules are not followed.

Once the pulse-train has been defined the period can be adjusted irrespective of the pulse width and delay settings for the individual pulses because, unlike a conventional pulse generator, the individual pulse widths and delays are adjusted **proportionally** to the period as the period is changed.

Period can also be changed from the **PULSE-TRN PERIOD** screen called by pressing the **FREQ** key with pulse-train mode selected:

```
◇PULS-TRN PER: int
      100.0000 us
◇freq      period◇
```

The new setting can be entered either as a period in the way already described or as a frequency by first pressing the **freq** soft-key. However, changing the period/frequency from this screen is slightly different from changing period on the **pulse-train setup** screen. When changing from this screen the number of points in the waveform is never changed (just as with a true arb) which means that the shortest period/highest frequency that can be set is the number of waveform points x 10.00ns. To achieve faster frequencies (up to the specification limit) the period must be changed from the pulse-train set-up screen; changing the frequency from the pulse-train set-up screen causes the number of points to be reduced as the period is reduced (for period <1.00ms).

Because Pulse-train waveforms are actually a particular form of arb and use Clock Synthesis mode, Pulse-train mode can also be operated with an external clock connected to the rear panel ARB CLOCK IN/OUT socket or the System Clock on multi-channel instruments. To select external clock mode press the **PULS-TRN PER** soft-key on the **PULS-TRN PER** screen (or the **PULSE FREQ** soft-key on the **PULSE FREQ** screen) to change from **internal** to **external** clock. The screen changes to, for example:

```
◇PULS-TRN PER: int
      source: ext arb clk
```

on a single channel instrument or:

```
◇PULS-TRN PER: int
      ◆source: ext arb clk
◇freq: 10.000000kHz
```



---

on a multi-channel instrument. It is then possible to select the source to be either an external signal on the ARB CLOCK IN/OUT socket or the Internal System Clock; see the Reference Clock IN/OUT and System Clock Setting sections of System Operations on the Utility Menu, for how to use and set the frequency of the System Clock.

Note that the Pulse-train waveform will continue to run from the internal clock until the instrument receives the first rising edge of the external clock; at that point the hardware switches over to the external source. In external clock mode the period of the Pulse-train waveform is determined by the number of points in the waveform x the period of the external clock. The external clock period is determined by the user; the number of points in the Pulse-train waveform can be found, **before selecting external clock**, by pressing the **set-up** soft-key beside **pulse-train** on the **STANDARD WAVEFORMS** screen.

## Waveform Hold in Pulse and Pulse-Train Modes

Pulse and Pulse-Train waveforms can be paused and re-started on any channel by using the front panel MAN HOLD key or a signal applied to the rear panel HOLD IN socket.

On multi-channel instruments the channels which are to be held by the MAN HOLD key or HOLD IN socket must first be enabled using the **ARB HOLD INPUT** screen, accessed by pressing the HOLD KEY.

```
ARB HOLD INPUT:
status: no hold
▲mode: disabled
```

Each channel is selected in turn using the channel SETUP keys and set using the **mode** soft-key; the mode changes between **disabled** and **enabled** with alternate key presses.

Pressing the front panel MAN HOLD key stops the waveform at the current level on all enabled channels; pressing MAN HOLD a second time restarts the waveform from that level. If the **ARB HOLD INPUT** screen is currently selected the **status** field will change from **no hold** to **manual hold** while the waveform is paused.

A logic low or switch closure at the rear panel HOLD IN socket also stops the waveform at the current level on all enabled channels; a logic high or switch opening restarts the waveform from that level. If the **ARB HOLD INPUT** screen is currently selected the **status** field will change from **no hold** to **ext. hold** whilst the waveform is paused.

## Introduction

Both internal and external modulation can be selected. External modulation can be applied to any or all channels. Internal modulation uses the previous channel as the modulation source, e.g. channel 2 can be used to modulate channel 3; internal modulation is not available on channel 1 or on a single channel instrument.

The external modulation mode can be set to VCA (Voltage Controlled Amplitude) or SCM (Suppressed Carrier Modulation) modes. Internal modulation can be set to true AM (Amplitude Modulation) or SCM.

Modulation modes share some of the generator's inter-channel resources with Sum modes; as a result there are some restrictions on using Modulation and Sum together but these are generally outside the range of common-sense applications. To better understand these constraints the following sections (and the SUM chapter) should be read with reference to the fold-out block diagrams at the end of the manual which show the control signals of a single channel and the inter-channel connections.

These diagrams also show the inter-channel trigger connections described in the Triggered Burst and Gate chapter; in general, inter-channel triggering is possible simultaneously with modulation but few combinations are of real use.

## External Modulation

Pressing the MODULATION key calls the **MODULATION** set-up screen.

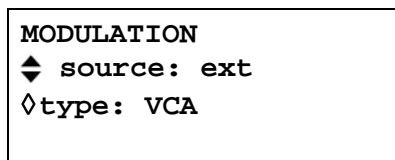

The **source** soft-key steps the modulation choice between **off**, **external** and **CHx** where **x** is the number of the previous channel; note that channel 1 does not have a previous channel, refer to the Inter-Channel Block Diagram.

With **ext** selected the modulation can be switched between **VCA** and **SCM** with alternate presses of the **type** soft-key. Both types of external modulation can be used with internal or external Sum. External modulation can be applied to any or all channels.

## External VCA

Select **VCA** with the **type** soft-key on the **MODULATION** screen. Connect the modulating signal to the MODULATION socket (nominally 1kΩ input impedance); a positive voltage increases the channel output amplitude and a negative voltage decreases the amplitude. Note that clipping will occur if the combination of channel amplitude setting and VCA signal attempts to drive the output above 20Vpp open-circuit voltage.

External AM is achieved by setting the channel to the required output level and applying the modulation signal (which can be AC coupled if required) at the appropriate level to obtain the modulation depth required. If the channel output level is changed the amplitude of the modulating signal will have to be changed to maintain the same modulation depth.

The VCA signal is applied to the amplifier chain prior to the output attenuators. The amplifier itself is controlled over a limited range (~10dB) and the full amplitude range of the channel is achieved by switching in up to five -10dB attenuation stages. Peak modulation cannot exceed the maximum of the "range" within which the channel output has been set by choice of amplitude setting. Whereas with internal AM the generator gives warnings when the combination of modulation depth and amplitude setting cause waveform clipping (see Internal Modulation section), it is up to the user to observe the waveforms when using external VCA and to make adjustments if the waveform is clipping. Note that it is not possible to give a simple guide as to where the "range" breakpoints are because the use of DC Offset, for example, changes these points.

---

Within each “range” the maximum output setting of the channel at which clipping is avoided is reduced from range maximum to half this value as modulation is increased from 0% to 100%; 100% modulation will be achieved at this mid-range setting with an external VCA signal of approximately 1Vpp.

It is also possible to modulate a DC level from the generator with a signal applied to the MODULATION socket, as follows. Set the generator to external trigger on the **TRIGGER IN** setup screen but do not apply a trigger signal to TRIG IN; select squarewave. The MAIN OUT is now set at the peak positive voltage defined by the amplitude setting; pressing the  $\pm$  key with **AMPLITUDE** displayed will set the level to the peak negative voltage. This DC level can now be modulated by the signal applied to the MODULATION input.

## External SCM

Select **SCM** with the **type** soft-key on the **MODULATION** screen. Connect the modulating signal to the MODULATION input (nominally 1k $\Omega$  input impedance). With no signal the carrier is fully suppressed; a positive or negative level change at the modulation input increases the amplitude of the carrier. Note that clipping will occur if the SCM signal attempts to drive the output above the 20Vpp open-circuit voltage.

Peak modulation, i.e. maximum carrier amplitude (20Vpp), is achieved with an external SCM level of approximately  $\pm 1V$ , i.e. a 2Vpp signal.

When external SCM is selected for a channel the amplitude control of that channel is disabled; the **AMPLITUDE** setup screen shows the message **fixed by SCM**.

## Internal Modulation

Pressing the MODULATION key calls the **MODULATION** setup screen.

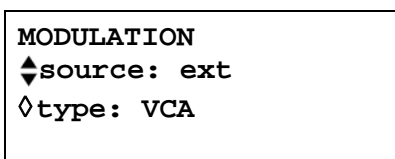

```
MODULATION
source: ext
type: VCA
```

The **source** soft-key steps the modulation choice between **off**, **external** and **CH<sub>x</sub>**, where **x** is the number of the previous channel; **CH<sub>x</sub>** is the source for internal modulation. Note that channel 1 and single channel instruments do not have a previous channel, i.e. they have no internal modulation capability; refer to the Inter-Channel Block Diagram.

With **CH<sub>x</sub>** selected the modulation mode can be switched between **AM** and **SCM** with alternate presses of the **type** soft-key.

When **AM** is selected the screen has an additional soft-key labelled **depth**; selecting this key permits the modulation depth to be set directly from the keyboard or by the rotary control.

Warnings are given when either a modulation depth or output amplitude change has caused clipping; the new setting is accepted but it must either be changed back or the other parameter must also be changed to avoid the contention.

When **SCM** is selected the screen has an additional soft-key labelled **level1**; selecting this key permits the peak carrier output level to be set directly from the keyboard or by the rotary control. The maximum output level that can be set is 10Vpp.

When internal SCM is selected for a channel both the amplitude control of that channel and the previous channel (used as the modulation source) are disabled. The **AMPLITUDE** setup screen of the channel being modulated shows the message **fixed by SCM**. The **AMPLITUDE** screen of the previous channel shows the message **Set by CH<sub>x</sub> mod.** and its status screen shows the message **→x** to indicate that it is being used as a source for channel x. Internal modulation cannot be used with internal or external Sum.

## Introduction

Both internal and external Sum can be selected; summing can be used to add 'noise' to a waveform, for example, or to add two signals for DTMF (Dual Tone Multiple Frequency) testing. External Sum can be applied to any or all channels. Internal sum uses the previous channel as the modulation source, e.g. channel 2 can be summed into Channel 3; internal Sum is not available on channel 1 or on a single channel instrument.

Summing shares some of the generator's inter-channel resources with Modulation modes; as a result neither internal nor external Sum can be used with internal modulation but external modulation is possible.

To better understand the constraints, the following sections (and the Modulation chapter) should be read with reference to the fold-out block diagrams at the end of the manual which show the control signals of a single channel and the inter-channel connections.

These diagrams also show the inter-channel trigger connections described in the Triggered Burst and Gate chapter; in general, inter-channel triggering is possible simultaneously with summing.

## External Sum

In Sum mode an external signal applied to the EXT SUM input is summed with the waveform(s) on the specified channel(s). The same Sum input signal can be used at different amplitudes with each of the channels with which it is summed.

Pressing the SUM key calls the `SUM` set-up screen.

SUM	source: ext	↕
◇CH2	+2.00	Vpp

Pressing the `source` soft-key steps the Sum sources between `off`, `external` and `CHx` where `x` is the number of the previous channel, refer to the Inter-Channel Block Diagram.

With `ext` selected the screen is as shown above.

Clipping will occur if the Sum input level attempts to drive the channel amplitude above the maximum 20Vpp open-circuit voltage. However, the relationship between the EXT SUM input and the maximum summed output depends not only on the Sum input level but also on the channel amplitude setting. This is because the Sum input is applied to the amplifier chain prior to the output attenuators; the amplifier itself is controlled over a limited range (~10dB) and the full amplitude range of the channel is achieved by switching in up to five -10dB attenuation stages. The summed output cannot exceed the maximum of the "range" within which the channel output has been set by choice of amplitude setting. Whereas with internal Sum the generator gives warnings when the combination of Sum input and amplitude would cause waveform clipping (see Internal Sum section), it is up to the user to observe the waveforms when using external sum and to make adjustments if the waveform is clipping. Note that it is not possible to give a simple guide as to where the "range" breakpoints are because the use of DC Offset, for example, changes these points.

Within each "range" an EXT SUM signal of ~2Vpp will force the channel output from range minimum to range maximum; if the channel amplitude is set to mid-range the EXT SUM signal needed to force the output to range maximum is about half, i.e. ~1Vpp.

To facilitate the setting of appropriate Sum and amplitude levels the output amplitude of the selected channel can also be changed from the `SUM` set-up screen. Press the `CHx` soft-key and adjust the amplitude with direct keyboard entries or by using the rotary knob.

External Sum cannot be used with internal modulation.

---

## Internal Sum

Pressing the SUM key calls the SUM set-up screen.

SUM	source: CH1	↕
◇ratio:	1.00000	
◇CH2:	2.00	Vpp
◇CH1:	2.00	Vpp

Pressing the **source** soft-key steps the Sum source between **off**, **external** and **CH<sub>x</sub>** where **x** is the number of the previous channel; **CH<sub>x</sub>** is the source of the internal Sum signal. Note that channel 1 and single channel instruments do not have a previous channel, refer to the Inter-Channel Block Diagram.

With **CH<sub>x</sub>** selected for internal Sum the screen is as shown above. The amplitude of both the summing channel ( **CH<sub>x+1</sub>** ) and the internal Sum signal ( **CH<sub>x</sub>** ) are shown in the display, together with the **ratio** between them. All three parameters can be selected with the appropriate soft-key and set directly from the keyboard or by the rotary control. Changing any one parameter will also adjust the interdependent one, e.g. adjusting the amplitude of either channel will cause the displayed ratio to change.

Note that the value shown in the **ratio** field is  $CH(x) \text{ amplitude} \div CH(x+1) \text{ amplitude}$ .

Adjusting the ratio value directly changes the amplitude of the Sum input signal, i.e.  $CH(x)$ , never the channel's output amplitude. When a value is entered into the **ratio** field it is initially accepted as entered but may then change slightly to reflect the actual ratio achieved with the nearest Sum input amplitude that could be set for the given channel output amplitude.

Warnings are given when either a ratio, Sum input or output amplitude change is attempted which would cause the channel output to be driven into "clipping".

In general it is recommended that the amplitude of the Sum input is smaller than the channel amplitude, i.e. the ratio is  $\leq 1$ ; most ratio values  $\leq 1$  can then be set, down to very small signal levels. If the Sum input is greater than the channel amplitude there will be combinations when the ratio can be set to a little more than 1. Note that the software will always accept an entry, make the calculation and, if the combination is not possible, return the instrument to the original setting.

The amplitude of the channel being used for the internal Sum signal can still be adjusted on its own Amplitude set-up screen; its status screen shows the message  $\rightarrow x$  to indicate that it is being used as a source for channel **x**.

Internal sum cannot be used with internal modulation.

---

# Inter-Channel Synchronisation

Two or more channels can be synchronised together and precise phase differences can be set between the channels. Two generators can also be synchronised (see Synchronising Two Generators chapter) giving a maximum of 8 channels that can be operated in synchronisation. Restrictions apply to certain waveform and frequency combinations; these are detailed in the following sections.

## Synchronising Principles

Frequency synchronising is achieved by using the clock output from a 'master' channel to drive the clock inputs of 'slaves'. Any channel can be a master (only 1 master allowed) and any or all the others can be slaves; master/slaves and independent channels can be mixed on the same instrument. When frequency synchronisation is switched on, the internal synchronising signal (from the CPU) synchronises the channels at the specified inter-channel phase and re-synchronises them automatically every time the frequency is changed. The clock and internal synchronisation signals are shown in the Inter-Channel Block Diagram at the end of the manual. Channels to be synchronised together must all be operating in continuous mode.

For DDS-generated waveforms (see Principles of Operation in the General chapter) it is the 100MHz signal that is distributed from master to slaves and channels can, in principle, be frequency-synchronised with any frequency combination. However, the number of cycles between the phase-referenced points will be excessively large unless the ratio is a small rational number,

e.g. 2kHz could be synchronised usefully with 10kHz, 50kHz, 100kHz, etc., but not with 2.001kHz, for example.

For Clock Synthesised waveforms (see Principles of Operation in the General chapter) it is the synthesised arb clock of the master which is distributed from master to slaves; the clock frequency for master and slaves is therefore always the same. The number of points comprising the waveforms should also be the same to ensure that the waveforms themselves appear locked.

From the foregoing it is clear that only DDS 'slaves' can be synchronised to a DDS 'master' and only Clock Synthesised 'slaves' can be synchronised to a Clock Synthesised 'master'. In practice the constraints described are not severe as the most common use of synchronisation is to provide outputs of the same waveform at the same frequency, or maybe a harmonic frequency, but with phase differences.

## Master-Slave Allocation

Press the front panel INTERChannel key to call up the inter-channel set-up screen.

```
◆mode: indep
◇phase:  +000.0°
  (actual: +000.0°)
◇status: off  view◇
```

The **mode** soft-key can be used to select between **independent**, **master**, **master/freq** and **slave**; the default mode is **independent**. Only one **master** can be set; more than one master can be selected but when synchronisation is turned on with the **status** soft-key the set-up will be rejected. **Master/freq** selects the master **and** sets frequency-tracking; for this to be operational the master and slave(s) must be set to the same frequency when synchronisation is turned on. In this mode, when the frequency of the master is changed the frequency of the slaves also change and the slaves are re-synchronised to the master.

**Master/freq** is the default mode when the waveforms are Clock Synthesised (arbs, pulses, etc); if **master** has been set instead, the mode will automatically change to **master/freq** when synchronisation is turned on. The frequency of Clock Synthesised waveform slaves always therefore tracks the master. Finally, **slave** selects those channel(s) which are to be synchronised to the master.

---

At any time, pressing the **view** soft-key gives a graphical view of the master-slave set-up, see below for an example.

```
CH→ 1 2 3 4
indep - - - Y
master Y- - -
slave - YY- exit◊
```

Channel synchronisation is turned on or off with the **status** soft-key. Any illegal setting combinations will result in an error message when an attempt is made to turn status on. Any of the following conditions will cause an error (see also the Synchronising Principles section for a discussion of the set-up constraints):

1. More than one master channel is enabled.
2. No master channel is enabled.
3. The synchronised channels contain a mixture of DDS and PLL generated waveforms.
4. Frequency tracking is enabled (mode: master/freq) but the frequencies are not the same on all channels. If Clock Synthesised waveforms are synchronised the mode will be forced to frequency tracking.
5. A synchronised channel is not set to continuous mode.
6. An attempt is made to turn on synchronisation with a frequency set too high.
7. An attempt is made to set the frequency too high with synchronisation on. This error does not set synchronisation to off; the system simply inhibits the setting of the incorrect frequency.

In addition to the illegal setting combinations there are further considerations which affect the phase resolution and accuracy between channels, see below.

### Phase-setting between Channels

The inter-channel set-up screen also has a field for setting up the phase of the slaves with respect to the master.

```
◄mode: indep
◊phase: +000.0°
(actual: +000.0°)
◊status: off view◊
```

Selecting the phase soft-key allows the phase to be set by direct keyboard entry or by rotary control. Setting the phase of a slave positive advances the waveform of the slave with respect to the master; setting it negative delays the slave with respect to the master. The phase of each slave channel can be set independently. The phase of the master can also be set; this is intended primarily for use when synchronising two generators. If both the master and the slaves are set to  $+90^\circ$ , say, on the same generator then the waveforms will all be in phase again; if the master is set to  $+90^\circ$  and the slaves set to  $-90^\circ$  the master and slave waveforms will be  $180^\circ$  out of phase.

DDS-generated waveforms can be synchronised with  $0.1^\circ$  resolution up to their maximum available frequency.

The phase-locking resolution of arbitrary waveforms will be less than  $0.1^\circ$  for waveforms of less than 3600 points. The phase is fixed at  $0^\circ$  for pulses, pulse-trains and sequences.

The table below summarises the phase control and frequency range for different waveforms.

Waveform	Max Wfm Freq	Phase Control Range & Resolution
Sine, cosine, haversine, havercosine	40MHz	$\pm 360^\circ$ , $0.1^\circ$
Square	50MHz	$\pm 360^\circ$ , $180^\circ$
Triangle	500kHz	$\pm 360^\circ$ , $0.1^\circ$
Ramp	500kHz	$\pm 360^\circ$ , $0.1^\circ$
Sin(x)/x	500kHz	$\pm 360^\circ$ , $0.1^\circ$
Pulse & Pulse Train	40MHz	$\pm 360^\circ$ , $360^\circ \div \text{length}$ or $0.1^\circ$
Arbitrary	100MS/s clock	$\pm 360^\circ$ , $360^\circ \div \text{length}$ or $0.1^\circ$
Sequence	100MS/s clock	$0^\circ$ only

### Other Synchronising Considerations

The Master–Slave Allocation and Phase–Setting sections contain tables of specific limitations on the selection of frequency, waveform type and phase–setting range and resolution. The following further points should also be considered.

- The waveform filters introduce a frequency–dependent delay above  $\sim 1\text{MHz}$ ; this will affect the accuracy of the phase between synchronised waveforms at different frequencies, e.g. 500kHz and 5MHz.
- Square waves, which are 2–point Clock Synthesised waveforms will not reliably synchronise to other Clock Synthesised waveforms.
- Pulse and Pulse train waveforms will synchronise to other Pulse and Pulse–trains (and each other) but should be **built** with equal periods.
- Arb waveforms should be the same length (although this is not forced and does not create an error message).

When synchronisation is turned on with the status soft–key the slaves are re-synchronised automatically after every phase or frequency setting change. This re-synchronisation may, depending on the type of waveforms used, cause an interruption of the waveforms as the phases are established. The following show the different possibilities when a frequency is changed.

1. **DDS waveforms with master mode set**

There will always be an interruption but this is the only condition which allows the frequencies of the waveform to be different.

2. **DDS waveforms with master/freq mode set.**

The frequencies of the waveforms will be the same and there will be no interruption.

3. **Clock Synthesised Waveforms**

Master/freq mode will be set automatically and there will always be an interruption when the frequency is changed.

4. **Clock Synthesised Waveforms with External Arb Clock Selected**

This is the recommended method for synchronising arbs and pulses. The channels must have external arb clock selected before they are synchronised. The ext arb clock may be provided by an external signal at the ARB CLOCK IN/OUT socket or by the System Clock.



---

# Synchronising Two Generators

Two generators can be synchronised together following the procedure outlined below. It is possible to link more than two generators in this way but results are not guaranteed.

## Synchronising Principles

Frequency synchronisation is achieved by using the clock output from the 'master' generator to drive the clock input of a slave. The additional connection of an initialising SYNC signal permits the slave to be synchronised such that the phase relationship between master and slave outputs is that specified on the slave generator's inter-channel set-up screen.

Synchronisation is only possible between generators when the ratio of the master and slave frequencies is rational, e.g. 3kHz can be synchronised with 2kHz but not with 7kHz. Special considerations arise with waveforms generated by Clock Synthesis mode (squarewave, arbitrary, pulse, pulse-train and sequence); with these waveforms, frequencies with an apparently rational relationship (e.g. 3:1) may be individually synthesised such that the ratio is not close enough to e.g. 3:1 to maintain synchronisation over a period of time; the only relationships guaranteed to be realised precisely are  $2^n:1$  because the division stages in Clock Synthesis mode are binary. A further complication arises with arb waveforms because waveform frequency depends on both waveform size and clock frequency (waveform frequency = clock frequency  $\div$  waveform size). The important relationship with arbs is the ratio of **clock** frequencies and the above considerations on precision apply to them. The most practical use of synchronisation will be to provide outputs at the same frequency, or maybe harmonics, but with phase differences.

## Connections for Synchronisation

The clock connection arrangement is for the rear panel REF CLOCK IN/OUT of the master (which will be set to **master**) to be connected directly to the REF CLOCK IN/OUT socket of the slave (which will be set to **slave**).

Similarly the synchronising connection is from any SYNC OUT of the master, which all default to **phase lock**, to the TRIG IN input of the slave.

## Generator Set-ups

Each generator can have its main parameters set to any value, with the exception that the ratio of frequencies between master and slave must be rational and each generator can be set to any waveform, but see Synchronising Principles section above. Best results will be achieved if the constraints forced on inter-channel synchronisation are adopted for inter-generator synchronisation.

The master has its REF CLOCK IN/OUT set to **master** on the **REF/SYS CLOCK** menu called by the **sys/ref** soft-key on the UTILITY screen, see System Operations section.

```
REF/SYS CLOCK:
▲sys clk: off
◊freq: 10.000000kHz
◊ref clk: master
```

Repeated presses of the **ref clk** soft-key toggle between the possibilities.

The slave is set to **slave**. Setting the master generator to **master** forces the mode to continuous and defaults the SYNC OUT output to phase lock. Only one of the SYNC OUTs is needed for inter-generator synchronisation; the others may be reset to other functions if required. The phase relationship between the slave and the master is set on the inter-channel set-up screen of the slave, accessed by pressing the INTERChannel key.

---

```
mode: indep
phase: +000.0°
(actual: +000.0°)
status: off view
```

The phase of the **slave generator** is set by adjusting the phase of the **master channel** on the slave generator's inter-channel set-up screen exactly as described in the Phase-setting between Channels section of the inter-channel Synchronisation chapter. The phase(s) of slave channel(s) on the slave generator are set up with respect to the master in the way described in that same section.

When a single generator, which has no Inter-channel set-up key or screen, is the slave, its phase is set on the TRIGGER/GATE SETUP screen, see Trigger Phase section of the Triggered Burst and Gate chapter.

The convention adopted for the phase relationship between generators is the same as that used between channels, i.e. a positive phase setting advances the slave generator with respect to the master and a negative setting delays the slave generator. The status of the slave generator on the inter-channel set-up screen must be set to on (automatic on a single channel generator).

Hardware delays become increasingly significant as frequency increases causing additional phase delay between the master and slave. However, these delays can be largely nulled-out by 'backing-off' the phase settings of the slave.

Typically these hardware delays are as follows:

DDS waveforms:  $<\pm 25\text{ns}; <1^\circ$  to 100kHz

Clock Synthesised waveforms:  $<300\text{ns}; <1^\circ$  to 10kHz.

Clearly a multi-channel generator gives much closer inter-channel phase-synchronisation and is the recommended method for up to 4 channels.

## Synchronising

Having made the connections and set up the generators as described in the preceding paragraphs, synchronisation is achieved by pressing the MAN TRIG key of the slave. Once synchronised any change to the setup will require resynchronisation with the MAN TRIG key again.

It is also possible to use an external arb clock when synchronising two generators. The generators are set up as described for internal clock but all channels are set to external clock. The same external clock should be applied to both generators.

---

## Memory Card and Other System Operations from the Utility Menu

Pressing the UTILITY key calls a list of menus which give access to various system operations including storing/recalling set-ups from a memory card, error messages, power on settings and calibration.

### Memory Card – General Information

The instrument uses compact flash memory cards, i.e. cards that comply with the Compact Flash Association standard. A compatible memory card and a USB card reader/writer are supplied with the instrument. The card reader/writer may be connected to a PC to allow waveform files created on the PC to be written directly to a memory card. The memory card may then be transferred to the instrument and the waveform played back immediately. Similarly waveforms created or modified on the instrument may be transferred to the PC.

To install the card reader/writer follow the instructions supplied with it. For Windows ME/2000/XP and later simply plug the device in to a spare USB port and Windows should detect it; for Windows 98/98SE the driver supplied will need to be installed from the CD.

On single channel instruments the memory slot is on the rear panel; on multi-channel instruments the memory card slot is on the front panel. Plug the memory card into the memory card slot ensuring that the pointer on the card aligns with the pointer on the panel. Push the card gently until it is fully engaged in the connector. The card may be inserted with the power on or off.

When a card is inserted in a powered instrument the message **Opening memory card** will appear on the bottom line of the screen, the MEMORY CARD ACTIVE lamp will light and a short beep will sound. The card is then ready for use as described in the ARB and SAVE/RECALL sections of this manual. To remove the memory card, ensure that the MEMORY CARD ACTIVE lamp is off and pull the card straight out of the slot. Never remove the memory card when the MEMORY CARD ACTIVE lamp is lit as this may cause the instrument firmware to malfunction, or lock up, resulting in corruption of the memory card data.

### Card Sizes and Formats

The instrument is compatible with cards ranging in capacity from 32MB to 1GB. From new these cards are formatted with the FAT16 file system. Cards with lower capacity will be formatted with the FAT12 file system which is not readable by the instrument. However, it is possible to reformat these smaller cards with the FAT16 file system in the instrument, from the **MEMORY CARD** screen, accessed by pressing the **memory card...** soft-key on the **UTILITY MENU**.

Take care when formatting memory cards in a PC as they will be formatted, by default, as FAT12 if they are under 32MB. Windows XP formats larger capacity cards FAT32 which is not readable by the instrument. It is also usual to lose a small amount of capacity when formatting using a PC; this is because the PC treats the card as a removable hard disk and leaves the first 'cylinder' blank. Any card formatted FAT16 by the instrument should work in a PC.

When a new or newly formatted card is inserted in the instrument for the first time it will be prepared for use by adding two directories to the root. These are \WAVES.ARB, where waveforms are stored, and \SETUP.ARB, where instrument setups are stored. The instrument will use these directories exclusively for its files. Each directory may hold up to 510 files, disk capacity permitting. If more than 510 files are stored in these directories some will be invisible to the instrument because its directory cache buffers are a finite size.

---

## **Saving Files to a Memory Card**

When creating files the instrument uses the 8.3 file naming format where the 8 is the 8 character filename and 3 is the file extension. The user chooses the filename and the instrument adds the extension. The instrument does not create Windows long filenames. If long filenames exist on the memory card they are ignored by the instrument and the 8.3 alias name is used instead and will appear on the lcd screen. If long filenames are allowed to get into the directories that the instrument uses they consume directory space and will reduce the maximum number of files that can be seen by the instrument. Unfortunately it is very easy to inadvertently create long filename entries when using the card reader/writer; simply saving a waveform as wave.wfm will create a long filename entry and an alias. This is because Windows takes the filename literally as it is entered and, as 8.3 filenames do not allow lower case, any lower case letter in a filename will produce a long filename. To avoid the problem in the above example it is necessary to save the file as WAVE.WFM.

The Waveform Manager application supplied will ensure that all filenames are short if the download to memory card function is used to transfer waveforms to the card reader/writer.

---

## System Operations from the Utility Menu

Each of the following operations are accessed by pressing the appropriate soft-key on the **UTILITY MENU**. Press **UTILITY** again at any time to return to the main Utility menu.

### Storing and Recalling Set-ups

Complete set-ups can be stored to or recalled from the memory card using the screens called by the **store** and **recall** soft-keys.

Pressing **store...** (or the **STORE** front panel key) calls the screen:

```
Save to store:
      "SETUP22 "
◇ execute
```

A unique store name must be entered using the ◀ and ▶ cursor keys and rotary control. The ◀ ▶ keys step the edit cursor through the 8 possible character positions of the name and the rotary control is used to scroll through all possible character choices.

Once the unique name has been entered, the current instrument set-up is saved to that store name by pressing the **execute** soft-key.

If the name already exists, the display changes to give the option to overwrite (**ok**) or **cancel**:

```
File SETUP22
exists,
overwrite?
◇ok          cancel◇
```

Up to 510 named stores can be accommodated on a memory card subject only to waveform length and card capacity.

Pressing **recall...** (or the **RECALL** front panel key) calls the **RECALL** screen:

```
RECALL:          execute◇
◇TESTWAVE        delete◇
◇SETUP6
◆SETUP22         default◇
```

The complete lists of all the set-ups stored on the memory card can be scrolled through the display using the rotary control. To make it easier to find a particular set-up in a long list it is recommended that the set-ups on the card are first sorted into alphabetical order using the sort facility on the **MEMORY CARD** screen, see later in this section.

The required set-up is selected with its corresponding soft-key and the recall is actioned with the **execute** soft-key. The factory defaults (see Appendix 3) can be recalled using the **default** soft-key. Note that loading the defaults does not change any arbitrary waveforms or set-ups stored on the memory card or the RS232/GPIB/USB interface settings. The selected set-up can also be deleted from the memory card using the **delete** soft-key.

### Channel Waveform Information

Pressing **chan wfm info...** calls the **CHANNEL WFM INFO** screen:

```
CHANNEL WFM INFO:
waveforms: 3
free mem: 142146
              exit ◇
```

---

This screen shows the number of arbitrary waveforms currently resident in the instrument's high speed memory and the number of free points for further waveforms. This is useful when constructing a large sequence of many waveforms as a guide to the spare memory remaining.

## Warnings and Error messages

The default setup is for all warning and error messages to be displayed and for a beep to sound with each message. This setup can be changed on the **error...** menu:

```
◇error beep: ON
◇error message: ON
▲warn beep: ON
◇warn message: ON
```

Each feature can be turned ON or OFF with alternate presses of the appropriate soft-key.

The last two error messages can be viewed by pressing the **last error...** soft-key. Each message has a number and the full list appears in Appendix 1. See also Warnings and Error Messages in the Standard Waveform Operation section.

## Remote Interface Setup

Pressing **remote...** calls the **REMOTE** setup screen which permits RS232/GPIB/USB choice and selection of address and Baud rate. Full details are given in the Remote Operation section.

## SYS/REF Clock In/Out and System Clock Setting

This screen allows the System Clock frequencies to be set and the ARB CLOCK IN/OUT socket to be set to input or output. There is no System Clock on a single channel instrument.

The ARB CLOCK IN/OUT socket is set to input by setting **SYStem CLOCK** to OFF and to an output by setting it to ON. When **SYS CLK** is ON (set to output) it is also used as the external clock when a channel is set to use an external arb clock.

The **SYS CLOCK** frequency may be set by numeric entry of rotary control.

Note that the **SYS CLK** frequency also controls the frequency of the aux sine output on the rear panel.

```
REF/SYS CLOCK:
▲sys clk: off
◇freq: 10.000000kHz
◇ref clk: input
```

The function of the rear panel REF CLOCK IN/OUT socket is set on the **SYS/REF CLOCK:** screen, called by pressing the **REF/SYS CLOCK** soft-key.

The default setting is for the socket to be set to **input**, i.e. an input for an external 10MHz reference clock. When set to **input** the system is automatically switched over to the external reference when an adequate signal level (TTL/CMOS threshold) is detected at REF CLOCK IN/OUT but will continue to run from the internal clock in the absence of such a signal.

With the clock set to **output** a buffered version of the internal 10MHz clock is made available at the socket.

With **master or slave** selected the socket can be set to be a **master or slave** when used for synchronising multiple generators. See Synchronising Generators section for full details.

---

## Memory Card Format and Directory Sorting

Pressing the **memory card...** soft-key calls the **MEMORY CARD** screen:

```
MEMORY CARD 61.0MB
label: TESTARB3
free: 59.6MB
◊format... sort dir...◊
```

The screen displays the memory card size, its name and the unused capacity. If either the WAVES or SETUP directories are full the screen will show **free: 0.0MB**. In addition, cards can be formatted to suit the instrument and the waveform and set-up directories can be sorted into alphabetical order.

The instrument requires cards formatted with the FAT16 file system, see Card Sizes and Formats section at the beginning of this chapter. This is the standard format for 32MB to 1GB cards when new but the format may have been changed if the card has been used elsewhere. To re-format for FAT16 press the **format...** soft-key followed by **ok** on the subsequent screen. The instrument will warn that re-formatting will cause any data on the card to be lost.

To sort the waveforms or set-ups into alphabetical order within their respective directories press **sort dir...** :

```
DIRECTORY SORT
◊sort waveforms
◊sort setups
◊cancel
```

Press the appropriate soft-key to sort the directory; pressing either **sort**, or **cancel** returns the display to the **MEMORY CARD** screen.

## Power On Setting

Pressing the **power on...** soft-key calls the **POWER ON SETTING** screen:

```
POWER ON SETTING
◊default values
◊restore last setup
▲recall SETUP22
```

The setting loaded at power on can be selected with the appropriate soft-key to be **default values** (the default setting), **restore last setup** (i.e. the settings at power down are restored at power up) or any of the settings stored on the memory card. The complete list of set-ups stored on the card can be scrolled through with further presses of the **recall** soft-key, the cursor keys or the rotary control. **default values** restores the factory default settings, see Appendix 3.

## System Information

The **system info...** soft-key calls the **SYSTEM INFO** screen which shows the instrument name and firmware revision. When **system info...** is pressed a checksum is also made of the firmware code and the result displayed; this can be used when a firmware fault is suspected, to check that the code has not got corrupted.

## Calibration

Pressing **calibration** calls the calibration routine, see Calibration section.

---

## Copying Channel Set-ups

An easy way of copying complete channel set-ups (waveform, frequency, amplitude, etc.) is accessed by pressing the COPY CHannel key.

```
copy channel: 1
▲to channel: 2
◇execute
```

The top line of the screen shows which channel is currently selected with the channel SETUP keys. Pressing the **to channel** soft-key steps the channel number through all the other channels of the instrument.

Select the channel to be changed and make the copy by pressing the **execute** soft-key.



All parameters can be calibrated without opening the case, i.e. the generator offers 'closed-box' calibration. All adjustments are made digitally with calibration constants stored in EEPROM. The calibration routine requires only a DVM and a frequency counter and takes no more than a few minutes.

The crystal in the timebase is pre-aged but a further ageing of up to  $\pm 5$ ppm can occur in the first year. Since the ageing rate decreases exponentially with time it is an advantage to recalibrate after the first 6 month's use. Apart from this it is unlikely that any other parameters will need adjustment.

Calibration should be carried out only after the generator has been operating for at least 30 minutes in normal ambient conditions.

## Equipment Required

- 3½ digit DVM with 0.25% DC accuracy and 0.5% AC accuracy at 1kHz.
- Frequency counter capable of measuring 10.00000MHz.

The DVM is connected to the MAIN OUT or SYNC OUT, as directed, of each channel in turn and the counter to any SYNC OUT.

Frequency meter accuracy will determine the accuracy of the generator's clock setting and should ideally be  $\pm 1$ ppm.

## Calibration Procedure

The calibration procedure is accessed by pressing the **calibration...** soft-key on the **UTILITY** screen.

```
CALIBRATION SELECTED
Are you sure ?
◇password...  tests...◇
◇exit        continue◇
```

The software provides for a 4-digit password in the range 0000 to 9999 to be used to access the calibration procedure. If the password is left at the factory default of 0000 no messages are shown and calibration can proceed as described in the Calibration Routine section; only if a non-zero password has been set will the user be prompted to enter the password.

## Setting the Password

On opening the Calibration screen press the **password...** soft-key to show the password screen:

```
ENTER NEW PASSWORD
_____
```

Enter a 4-digit password from the keyboard; the display will show the message **NEW PASSWORD STORED!** for two seconds and then revert to the **UTILITY** menu. If any keys other than 0-9 are pressed while entering the password the message **ILLEGAL PASSWORD!** will be shown.

## Using the Password to Access Calibration or Change the Password

With the password set, pressing **calibration...** on the **UTILITY** screen will now show:

```
ENTER PASSWORD
-----
```

---

When the correct password has been entered from the keyboard the display changes to the opening screen of the calibration routine and calibration can proceed as described in the Calibration Routine section. If an incorrect password is entered the message **INCORRECT PASSWORD!** is shown for two seconds before the display reverts to the **UTILITY** menu.

With the opening screen of the calibration routine displayed after correctly entering the password, the password can be changed by pressing **password...** soft-key and following the procedure described in Setting the Password. If the password is set to 0000 again, password protection is removed.

The password is held in EEPROM and will not be lost when the memory battery back-up is lost. In the event of the password being forgotten, contact the manufacturer for help in resetting the instrument.

## Calibration Routine

The calibration procedure proper is entered by pressing **continue** on the opening Calibration screen; pressing **exit** returns the display to the **UTILITY** menu. Pressing **tests...** calls a menu of basic hardware checks used at production test; these are largely self-explanatory but details can be found in the Service Manual if required. At each step the display changes to prompt the user to adjust the rotary control or cursor keys, until the reading on the specified instrument is at the value given. The cursor keys provide coarse adjustment, and the rotary control fine adjustment. Pressing **next** increments the procedure to the next step; pressing CE decrements back to the previous step. Alternatively, pressing **exit** returns the display to the last CAL screen at which the user can choose to either **save new values**, **recall old values** or **calibrate again**.

The first two displays (CAL 00 and CAL 01) specify the connections and adjustment method. The next display (CAL 02) allows the starting channel to be chosen; this allows quick access to any particular channel. To calibrate the complete instrument choose the default setting of CH1. The subsequent displays, CAL 03 to CAL 115 permit all adjustable parameters to be calibrated.

The full procedure is as follows:

CAL 03	CH1. DC offset zero.	Adjust for $0V \pm 5mV$
CAL 04	CH1. DC offset at + full scale.	Adjust for $+ 10V \pm 10mV$
CAL 05	CH1. DC offset at - full scale.	Check for $-10V \pm 3\%$
CAL 06	CH1. Multiplier zero.	Adjust for minimum Volts AC
CAL 07	CH1. Multiplier offset.	Adjust for $0V \pm 5mV$
CAL 08	CH1. Waveform offset.	Adjust for $0V \pm 5mV$
CAL 09	CH1. Output level at full-scale	Adjust for $10V \pm 10mV$
CAL 10	CH1. 20dB attenuator	Adjust for $1V \pm 1mV$
CAL 11	CH1. 40dB attenuator	Adjust for $0.1V \pm .1mV$
CAL 12	CH1. 10dB attenuator	Adjust for $2.236V AC \pm 10mV$
CAL 13	CH1. Not used.	
CAL 14	CH1. Not used.	
CAL 15	CH1. Not used.	
CAL 16	CH1. Level 0.1 MHz	Note reading
CAL 17	CH1. Level 33MHz	Check reading
CAL 18	CH1. Level 1MHz	Adjust for same reading
CAL 19	CH1. Level 2MHz	Adjust for same reading
CAL 20	CH1. Level 4MHz	Adjust for same reading
CAL 21	CH1. Level 5MHz	Adjust for same reading
CAL 22	CH1. Level 10MHz	Adjust for same reading

---

CAL 23	CH1. Level 15MHz	Adjust for same reading
CAL 24	CH1. Level 20MHz	Adjust for same reading
CAL 25	CH1. Level 25MHz	Adjust for same reading
CAL 26	CH1. Level 30MHz	Adjust for same reading
CAL 27	CH1. Level 32.5MHz	Adjust for same reading
CAL 28	CH1. Level 35MHz	Adjust for same reading
CAL 29	CH1. Level 37.5MHz	Adjust for same reading
CAL 30	CH1. Level 40MHz	Adjust for same reading
CAL 31	CH2. DC offset zero.	Adjust for $0V \pm 5mV$
CAL 32	CH2. DC offset at + full scale.	Adjust for $+ 10V \pm 10mV$
CAL 33	CH2. DC offset at – full scale.	Check for $-10V \pm 3\%$
CAL 34	CH2. Multiplier zero.	Adjust for minimum Volts AC
CAL 35	CH2. Multiplier offset.	Adjust for $0V \pm 5mV$
CAL 36	CH2. Waveform offset.	Adjust for $0V \pm 5mV$
CAL 37	CH2. Output level at full–scale	Adjust for $10V \pm 10mV$
CAL 38	CH2. 20dB attenuator	Adjust for $1V \pm 1mV$
CAL 39	CH2. 40dB attenuator	Adjust for $0.1V \pm .1mV$
CAL 40	CH2. 10dB attenuator	Adjust for $2.236V AC \pm 10mV$
CAL 41	CH2. Sum Offset	Adjust for $0V \pm 5mV$
CAL 42	CH2. SCM level at full-scale	Adjust for $5V \pm 5mV$
CAL 43	CH2. AM level at full-scale	Adjust for $10V \pm 10mV$
CAL 44	CH2. Level 0.1 MHz	Note reading
CAL 45	CH2. Level 33MHz	Check reading
CAL 46	CH2. Level 1MHz	Adjust for same reading
CAL 47	CH2. Level 2MHz	Adjust for same reading
CAL 48	CH2. Level 4MHz	Adjust for same reading
CAL 49	CH2. Level 5MHz	Adjust for same reading
CAL 50	CH2. Level 10MHz	Adjust for same reading
CAL 51	CH2. Level 15MHz	Adjust for same reading
CAL 52	CH2. Level 20MHz	Adjust for same reading
CAL 53	CH2. Level 25MHz	Adjust for same reading
CAL 54	CH2. Level 30MHz	Adjust for same reading
CAL 55	CH2. Level 32.5MHz	Adjust for same reading
CAL 56	CH2. Level 35MHz	Adjust for same reading
CAL 57	CH2. Level 37.5MHz	Adjust for same reading
CAL 58	CH2. Level 40MHz	Adjust for same reading
CAL 59	CH3. DC offset zero.	Adjust for $0V \pm 5mV$
CAL 60	CH3. DC offset at + full scale.	Adjust for $+ 10V \pm 10mV$
CAL 61	CH3. DC offset at – full scale.	Check for $-10V \pm 3\%$
CAL 62	CH3. Multiplier zero.	Adjust for minimum Volts AC
CAL 63	CH3. Multiplier offset.	Adjust for $0V \pm 5mV$
CAL 64	CH3. Waveform offset.	Adjust for $0V \pm 5mV$
CAL 65	CH3. Output level at full–scale	Adjust for $10V \pm 10mV$
CAL 66	CH3. 20dB attenuator	Adjust for $1V \pm 1mV$

---

---

CAL 67	CH3. 40dB attenuator	Adjust for $0.1V \pm .1mV$
CAL 68	CH3. 10dB attenuator	Adjust for $2.236V AC \pm 10mV$
CAL 69	CH3. Sum Offset	Adjust for $0V \pm 5mV$
CAL 70	CH3. SCM level at full-scale	Adjust for $5V \pm 5mV$
CAL 71	CH3. AM level at full-scale	Adjust for $10V \pm 10mV$
CAL 72	CH3. Level 0.1 MHz	Note reading
CAL 73	CH3. Level 33MHz	Check reading
CAL 74	CH3. Level 1MHz	Adjust for same reading
CAL 75	CH3. Level 2MHz	Adjust for same reading
CAL 76	CH3. Level 4MHz	Adjust for same reading
CAL 77	CH3. Level 5MHz	Adjust for same reading
CAL 78	CH3. Level 10MHz	Adjust for same reading
CAL 79	CH3. Level 15MHz	Adjust for same reading
CAL 80	CH3. Level 20MHz	Adjust for same reading
CAL 81	CH3. Level 25MHz	Adjust for same reading
CAL 82	CH3. Level 30MHz	Adjust for same reading
CAL 83	CH3. Level 32.5MHz	Adjust for same reading
CAL 84	CH3. Level 35MHz	Adjust for same reading
CAL 85	CH3. Level 37.5MHz	Adjust for same reading
CAL 86	CH3. Level 40MHz	Adjust for same reading
CAL 87	CH4. DC offset zero.	Adjust for $0V \pm 5mV$
CAL 88	CH4. DC offset at + full scale.	Adjust for $+ 10V \pm 10mV$
CAL 89	CH4. DC offset at – full scale.	Check for $-10V \pm 3%$
CAL 90	CH4. Multiplier zero.	Adjust for minimum Volts AC
CAL 91	CH4. Multiplier offset.	Adjust for $0V \pm 5mV$
CAL 92	CH4. Waveform offset.	Adjust for $0V \pm 5mV$
CAL 93	CH4. Output level at full-scale	Adjust for $10V \pm 10mV$
CAL 94	CH4. 20dB attenuator	Adjust for $1V \pm 1mV$
CAL 95	CH4. 40dB attenuator	Adjust for $0.1V \pm .1mV$
CAL 96	CH4. 10dB attenuator	Adjust for $2.236V AC \pm 10mV$
CAL 97	CH4. Sum Offset	Adjust for $0V \pm 5mV$
CAL 98	CH4. SCM level at full-scale	Adjust for $5V \pm 5mV$
CAL 99	CH4. AM level at full-scale	Adjust for $10V \pm 10mV$
CAL 100	CH4, Level 0.1 MHz	Note reading
CAL 101	CH4, Level 33MHz	Check reading
CAL 102	CH4, Level 1MHz	Adjust for same reading
CAL 103	CH4. Level 2MHz	Adjust for same reading
CAL 104	CH4. Level 4MHz	Adjust for same reading
CAL 105	CH4. Level 5MHz	Adjust for same reading
CAL 106	CH4. Level 10MHz	Adjust for same reading
CAL 107	CH4. Level 15MHz	Adjust for same reading
CAL 108	CH4. Level 20MHz	Adjust for same reading
CAL 109	CH4. Level 25MHz	Adjust for same reading

---

---

CAL 110	CH4. Level 30MHz	Adjust for same reading
CAL 111	CH4. Level 32.5MHz	Adjust for same reading
CAL 112	CH4. Level 35MHz	Adjust for same reading
CAL 113	CH4. Level 37.5MHz	Adjust for same reading
CAL 114	CH4. Level 40MHz	Adjust for same reading
CAL 115	Clock calibrate	Adjust for 10.00000 MHz at SYNC OUT.

## Remote Calibration

Calibration of the instrument may be performed over the RS232, GPIB or USB interface. To completely automate the process the multimeter and frequency meter will also need to be remote controlled and the controller will need to run a calibration program unique to this instrument.

The remote calibration commands allow a simplified version of manual calibration to be performed by issuing commands from the controller. The controller must send the CALADJ command repeatedly and read the dmm or frequency meter until the required result for the selected calibration step is achieved. The CALSTEP command is then issued to accept the new value and move to the next step.

While in remote calibration mode very little error checking is performed and it is the controllers responsibility to ensure that everything progresses in an orderly way. Only the following commands should be used during calibration.

**WARNING:** Using any other commands while in calibration mode may give unpredictable results and could cause the instrument to lock up, requiring the power to be cycled to regain control.

CALIBRATION <cpd> [,nrf]	The calibration control command. <cpd> can be one of three sub-commands:-
START	Enter calibration mode; this command must be issued before any other calibration commands will be recognised.
SAVE	Finish calibration, save the new values and exit calibration mode.
ABORT	Finish calibration, do not save the new values and exit calibration mode.
	<nrf> represents the calibration password. The password is only required with CALIBRATION START and then only if a non-zero password has been set from the instrument's keyboard. The password will be ignored, and will give no errors, at all other times. It is not possible to set or change the password using remote commands.
CALADJ <nrf>	Adjust the selected calibration value by <nrf>. The value must be in the range -100 to +100. Once an adjustment has been completed and the new value is as required the CALSTEP command must be issued for the new value to be accepted.
CALSTEP	Step to the next calibration point.

For general information on remote operation and remote command formats, refer to the following sections.

The instrument can be remotely controlled via its RS232, USB or GPIB interfaces. When using RS232 it can either be the only instrument connected to the controller or it can be part of an addressable RS232 system which permits up to 32 instruments to be addressed from one RS232 port.

Some of the following sections are general and apply to all 4 modes (single instrument RS232, addressable RS232, USB and GPIB); others are clearly only relevant to a particular interface or mode. It is only necessary to read the general sections plus those specific to the intended remote control mode.

Remote command format and the remote commands themselves are detailed in the Remote Commands chapter.

### Address and Baud Rate Selection

For successful operation, each instrument connected to the GPIB, USB or addressable RS232 system must be assigned a unique address and, in the case of addressable RS232, all must be set to the same Baud rate.

The instrument's remote address for operation on both the RS232 and GPIB interfaces is set via the `remote` screen on the UTILITY menu:

```
REMOTE:
◆Interface: RS232
◇address: 05
◇baud rate: 9600
```

With `interface` selected with the `interface` soft-key, the selection can be stepped between RS232, USB and GPIB with successive presses of the soft-key, the cursor keys or by using the rotary control.

With `address` selected, the soft-key, cursor keys or rotary control can be used to set the address.

The address setting is used in USB mode to allow the PC to access up to 30 different instruments.

With `baud rate` selected, the soft-key, cursor keys or rotary control can be used to set the baud rate for the RS232 interface.

When operating on the GPIB all device operations are performed through a single primary address; no secondary addressing is used.

NOTE: GPIB address 31 is not allowed by the IEEE 488 standards but it is possible to select it as an RS232 address.

### Remote/Local Operation

At power-on the instrument will be in the local state with the REMOTE lamp off. In this state all keyboard operations are possible. When the instrument receives a command the remote state will be entered and the REMOTE lamp will be turned on. In this state the keyboard is locked out and remote commands only will be processed. The instrument may be returned to the local state by pressing the LOCAL key; however, the effect of this action will remain only until the instrument is addressed again or receives another character from the interface, when the remote state will once again be entered.

# RS232 Interface

## RS232 Interface Connector

The 9-way D-type serial interface connector is located on the instrument rear panel. The pin connections are as shown below:

Pin	Name	Description
1	–	No internal connection
2	TXD	Transmitted data from instrument
3	RXD	Received data to instrument
4	–	No internal connection
5	GND	Signal ground
6	–	No internal connection
7	RXD2	Secondary received data (addressable RS232 only)
8	TXD2	Secondary transmitted data (addressable RS232 only)
9	GND	Signal ground (addressable RS232 only)

## Single Instrument RS232 Connections

For single instrument remote control only pins 2, 3 and 5 are connected to the PC. However, for correct operation links must be made in the connector at the PC end between pins 1, 4 and 6 and between pins 7 and 8, see diagram. Pins 7 and 8 of the instrument must **not** be connected to the PC, i.e. do not use a fully wired 9-way cable.

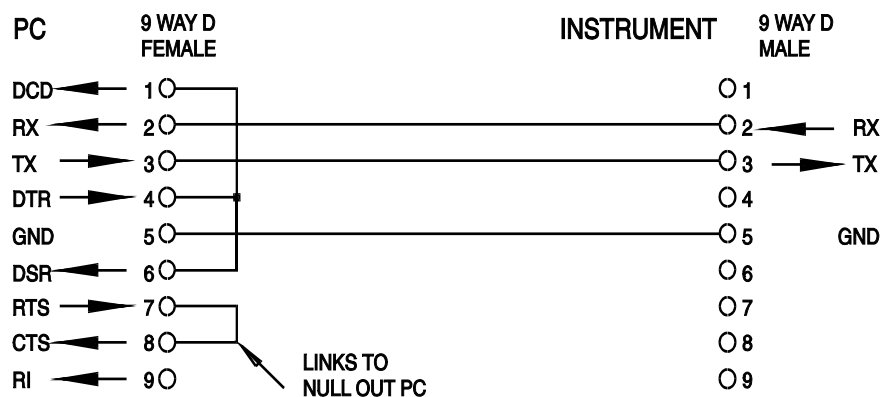

Baud Rate is set as described above in Address and Baud Rate Selection; the other parameters are fixed as follows:

Start Bits: 1                      Parity: None  
 Data Bits: 8                        Stop Bits: 1

## Addressable RS232 Connections

For addressable RS232 operation pins 7, 8 and 9 of the instrument connector are also used. Using a simple cable assembly, a 'daisy chain' connection system between any number of instruments, up to the maximum of 32 can be made, as shown below:

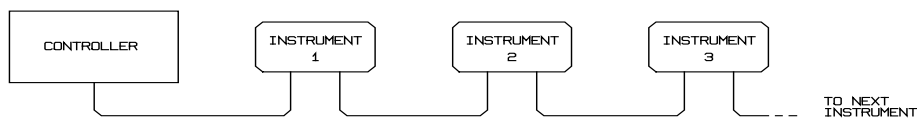

The daisy chain consists of the transmit data (TXD), receive data (RXD) and signal ground lines only. There are no control/handshake lines. This makes XON/XOFF protocol essential and allows the inter-connection between instruments to contain just 3 wires. The wiring of the adaptor cable is shown below:

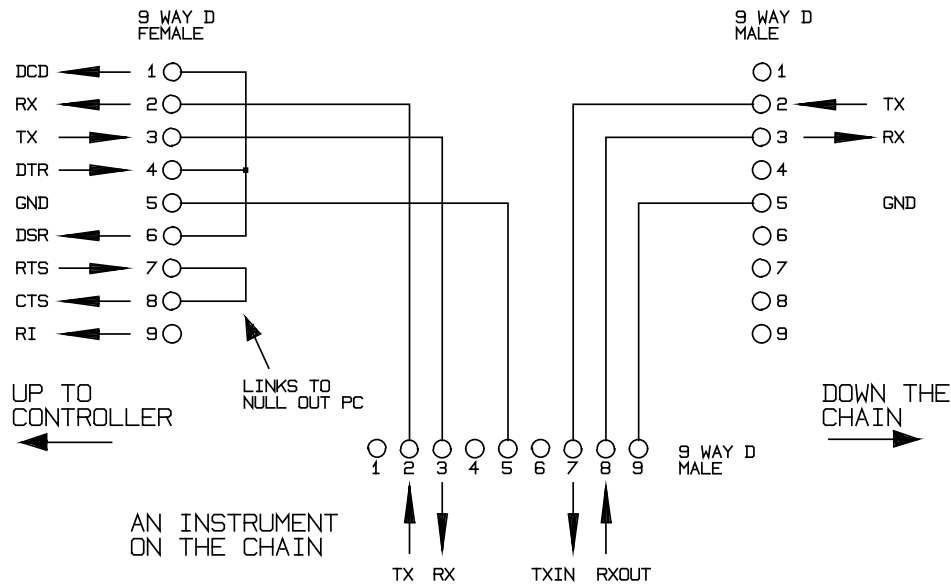

All instruments on the interface must be set to the same baud rate and all must be powered on, otherwise instruments further down the daisy chain will not receive any data or commands.

The other parameters are fixed as follows:

Start Bits: 1

Parity: None

Data Bits: 8

Stop Bits: 1

## RS232 Character Set

Because of the need for XON/XOFF handshake it is possible to send ASCII coded data only; binary blocks are not allowed. Bit 7 of ASCII codes is ignored, i.e. assumed to be low. No distinction is made between upper and lower case characters in command mnemonics and they may be freely mixed. The ASCII codes below 20H (space) are reserved for addressable RS232 interface control. In this manual 20H, etc. means 20 in hexadecimal

## Addressable RS232 Interface Control Codes

All instruments intended for use on the addressable RS232 bus use the following set of interface control codes. Codes between 00H and 1FH which are not listed here as having a particular meaning are reserved for future use and will be ignored. Mixing interface control codes inside instrument commands is not allowed except as stated below for CR and LF codes and XON and XOFF codes.

When an instrument is first powered on it will automatically enter the Non-Addressable mode. In this mode the instrument is not addressable and will not respond to any address commands. This allows the instrument to function as a normal RS232 controllable device. This mode may be locked by sending the Lock Non-Addressable mode control code, 04H. The controller and instrument can now freely use all 8 bit codes and binary blocks but all interface control codes are ignored. To return to addressable mode the instrument must be powered off.

To enable addressable mode after an instrument has been powered on the Set Addressable Mode control code, 02H, must be sent. This will then enable all instruments connected to the addressable RS232 bus to respond to all interface control codes. To return to Non-Addressable mode the Lock Non-Addressable mode control code must be sent which will disable addressable mode until the instruments are powered off.

Before an instrument is sent a command it must be addressed to listen by sending the Listen Address control code, 12H, followed by a single character which has the lower 5 bits corresponding to the unique address of the required instrument, e.g. the codes A-Z or a-z give the addresses 1-26 inclusive while @ is address 0 and so on. Once addressed to listen the instrument will read and act upon any commands sent until the listen mode is cancelled.



---

Because of the asynchronous nature of the interface it is necessary for the controller to be informed that an instrument has accepted the listen address sequence and is ready to receive commands. The controller will therefore wait for Acknowledge code, 06H, before sending any commands. The addressed instrument will provide this Acknowledge. The controller should time-out and try again if no Acknowledge is received within 5 seconds.

Listen mode will be cancelled by any of the following interface control codes being received:

- 12H Listen Address followed by an address not belonging to this instrument.
- 14H Talk Address for any instrument.
- 03H Universal Unaddress control code.
- 04H Lock Non-Addressable mode control code.
- 18H Universal Device Clear.

Before a response can be read from an instrument it must be addressed to talk by sending the Talk Address control code, 14H, followed by a single character which has the lower 5 bits corresponding to the unique address of the required instrument, as for the listen address control code above. Once addressed to talk the instrument will send the response message it has available, if any, and then exit the talk addressed state. Only one response message will be sent each time the instrument is addressed to talk.

Talk mode will be cancelled by any of the following interface control codes being received:

- 12H Listen Address for any instrument.
- 14H Talk Address followed by an address not belonging to this instrument.
- 03H Universal Unaddress control code.
- 04H Lock Non-Addressable mode control code.
- 18H Universal Device Clear.

Talk mode will also be cancelled when the instrument has completed sending a response message or has nothing to say.

The interface code 0AH (LF) is the universal command and response terminator; it must be the last code sent in all commands and will be the last code sent in all responses.

The interface code 0DH (CR) may be used as required to aid the formatting of commands; it will be ignored by all instruments. Most instruments will terminate responses with CR followed by LF.

The interface code 13H (XOFF) may be sent at any time by a listener (instrument or controller) to suspend the output of a talker. The listener must send 11H (XON) before the talker will resume sending. This is the only form of handshake control supported by the addressable RS232 mode.

#### *Full List of Addressable RS232 Interface Control Codes*

- 02H Set Addressable Mode.
- 03H Universal Unaddress control code.
- 04H Lock Non-Addressable mode control code.
- 06H Acknowledge that listen address received.
- 0AH Line Feed (LF); used as the universal command and response terminator.
- 0DH Carriage Return (CR); formatting code, otherwise ignored.
- 11H Restart transmission (XON).
- 12H Listen Address – must be followed by an address belonging to the required instrument.
- 13H Stop transmission (XOFF).
- 14H Talk Address – must be followed by an address belonging to the required instrument.
- 18H Universal Device Clear.

---

## USB Interface

The USB interface allows the instrument to be controlled via a PC's USB port. The instrument is supplied with a CD containing drivers for various versions of Windows, including Win98 and 2000. Any driver updates are available via the TTI website, <http://www.aimtti.com/support>. The CD also contains a .pdf file with information and details of the software installation procedure.

Installation of the driver is achieved by connecting the instrument to a PC via a standard USB cable. The Windows' plug and play functions should automatically recognise the addition of new hardware attached to the USB interface and if this is the first time the connection has been made, prompt for the location of a suitable driver. Provided that the standard Windows prompts are followed correctly Windows will install the appropriate driver. The driver will remain installed on the PC and should be called automatically each time the instrument is connected to the PC via USB in the future.

When the instrument is connected to a PC, with the correct driver installed, there will be an exchange of information between PC and instrument called the Enumeration process; this 'connects' the two together. It is possible to connect several instruments of the same type at the same time and the PC will be able to communicate with each one individually. To make it easy for an application program to direct commands to the required instrument the driver interrogates each instrument as it is connected to get its address. The application program can then access the instruments individually by that address.

The waveform design software supplied with this generator has been enhanced to permit downloads to the instrument using USB. For users wishing to write their own application software for USB communication with the generator, the relevant information is supplied on the CD containing the drivers themselves.

## GPIB Interface

The 24-way GPIB connector is located on the instrument rear panel. The pin connections are as specified in IEEE Std. 488.1-1987 and the instrument complies with IEEE Std. 488.1-1987 and IEEE Std. 488.2-1987.

### GPIB Subsets

This instrument contains the following IEEE 488.1 subsets:

Source Handshake	SH1
Acceptor Handshake	AH1
Talker	T6
Listener	L4
Service Request	SR1
Remote Local	RL1
Parallel Poll	PP1
Device Clear	DC1
Device Trigger	DT1
Controller	C0
Electrical Interface	E2

### GPIB IEEE Std. 488.2 Error Handling

The IEEE 488.2 UNTERMINATED error (addressed to talk with nothing to say) is handled as follows. If the instrument is addressed to talk and the response formatter is inactive and the input queue is empty then the UNTERMINATED error is generated. This will cause the Query Error bit to be set in the Standard Event Status Register, a value of 3 to be placed in the Query Error Register and the parser to be reset. See the Status Reporting section for further information.

The IEEE 488.2 INTERRUPTED error is handled as follows. If the response formatter is waiting to send a response message and a <PROGRAM MESSAGE TERMINATOR> has been read by the parser or the input queue contains more than one END message then the instrument has been INTERRUPTED and an error is generated. This will cause the Query Error bit to be set in the Standard Event Status Register, a value of 1 to be placed in the Query Error Register and the response formatter to be reset thus clearing the output queue. The parser will then start parsing the next <PROGRAM MESSAGE UNIT> from the input queue. See the Status Reporting section for further information.

The IEEE 488.2 DEADLOCK error is handled as follows. If the response formatter is waiting to send a response message and the input queue becomes full then the instrument enters the DEADLOCK state and an error is generated. This will cause the Query Error bit to be set in the Standard Event Status Register, a value of 2 to be placed in the Query Error Register and the response formatter to be reset thus clearing the output queue. The parser will then start parsing the next <PROGRAM MESSAGE UNIT> from the input queue. See the Status Reporting section for further information.

## GPIB Parallel Poll

Complete parallel poll capabilities are offered on this generator. The Parallel Poll Enable Register is set to specify which bits in the Status Byte Register are to be used to form the *ist* local message. The Parallel Poll Enable Register is set by the \*PRE <nrf> command and read by the \*PRE? command. The value in the Parallel Poll Enable Register is ANDed with the Status Byte Register; if the result is zero then the value of *ist* is 0 otherwise the value of *ist* is 1.

The instrument must also be configured so that the value of *ist* can be returned to the controller during a parallel poll operation. The instrument is configured by the controller sending a Parallel Poll Configure command (PPC) followed by a Parallel Poll Enable command (PPE). The bits in the PPE command are shown below:

bit 7 =	X	don't care
bit 6 =	1	Parallel poll enable
bit 5 =	1	
bit 4 =	0	
bit 3 =	Sense	sense of the response bit; 0 = low, 1 = high
bit 2 =	?	bit position of the response
bit 1 =	?	
bit 0 =	?	

*Example.* To return the RQS bit (bit 6 of the Status Byte Register) as a 1 when true and a 0 when false in bit position 1 in response to a parallel poll operation send the following commands

\*PRE 64<pmt>, then PPC followed by 69H (PPE)

The parallel poll response from the generator will then be 00H if RQS is 0 and 01H if RQS is 1.

During parallel poll response the DIO interface lines are resistively terminated (passive termination). This allows multiple devices to share the same response bit position in either wired-AND or wired-OR configuration, see IEEE 488.1 for more information.

## Status Reporting

This section describes the complete status model of the instrument. Note that some registers are specific to the GPIB section of the instrument and are of limited use in an RS232 environment.

---

## Standard Event Status and Standard Event Status Enable Registers

These two registers are implemented as required by the IEEE std. 488.2.

Any bits set in the Standard Event Status Register which correspond to bits set in the Standard Event Status Enable Register will cause the ESB bit to be set in the Status Byte Register.

The Standard Event Status Register is read and cleared by the \*ESR? command. The Standard Event Status Enable register is set by the \*ESE <nrf> command and read by the \*ESE? command.

- Bit 7 – Power On. Set when power is first applied to the instrument.
- Bit 6 – Not used.
- Bit 5 – Command Error. Set when a syntax type error is detected in a command from the bus. The parser is reset and parsing continues at the next byte in the input stream.
- Bit 4 – Execution Error. Set when an error is encountered while attempting to execute a completely parsed command. The appropriate error number will be reported in the Execution Error Register.
- Bit 3 – Not used.
- Bit 2 – Query Error. Set when a query error occurs. The appropriate error number will be reported in the Query Error Register as listed below.
  - 1. Interrupted error
  - 2. Deadlock error
  - 3. Unterminated error
- Bit 1 – Not used.
- Bit 0 – Operation Complete. Set in response to the \*OPC command.

## Status Byte Register and Service Request Enable Register

These two registers are implemented as required by the IEEE std. 488.2.

Any bits set in the Status Byte Register which correspond to bits set in the Service Request Enable Register will cause the RQS/MSS bit to be set in the Status Byte Register, thus generating a Service Request on the bus.

The Status Byte Register is read either by the \*STB? command, which will return MSS in bit 6, or by a Serial Poll which will return RQS in bit 6. The Service Request Enable register is set by the \*SRE <nrf> command and read by the \*SRE? command.

- Bit 7 – Not used.
- Bit 6 – RQS/MSS. This bit, as defined by IEEE Std. 488.2, contains both the Requesting Service message and the Master Status Summary message. RQS is returned in response to a Serial Poll and MSS I–s returned in response to the \*STB? command.
- Bit 5 – ESB. The Event Status Bit. This bit is set if any bits set in the Standard Event Status Register correspond to bits set in the Standard Event Status Enable Register.
- Bit 4 – MAV. The Message Available Bit. This will be set when the instrument has a response message formatted and ready to send to the controller. The bit will be cleared after the Response Message Terminator has been sent.
- Bit 3 – Not used.
- Bit 2 – Not used.
- Bit 1 – Not used.
- Bit 0 – Not used.

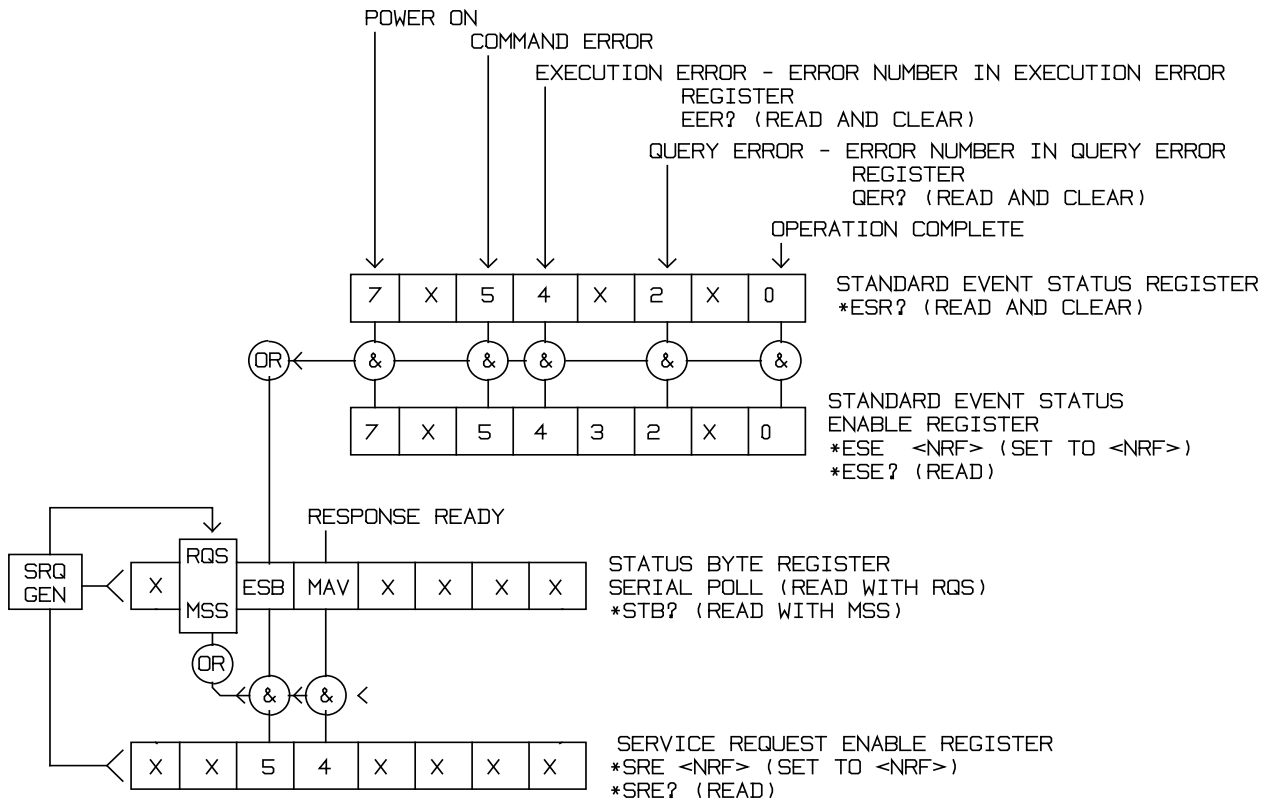

## Status Model

## Power on Settings

The following instrument status values are set at power on:

Status Byte Register	= 0
Service Request Enable Register †	= 0
Standard Event Status Register	= 128 (pon bit set)
Standard Event Status Enable Register †	= 0
Execution Error Register	= 0
Query Error Register	= 0
Parallel Poll Enable Register †	= 0

† Registers marked thus are specific to the GPIB section of the instrument and are of limited use in an RS232 environment.

The instrument will be in local state with the keyboard active.

The instrument parameters at power on are determined on the **POWER ON SETTING** screen accessed from the **UTILITY** menu. If **restore last setup** or **recall store no. nn** has been set and a defined state is required by the controller at start up then the command **\*RST** should be used to load the system defaults.

If for any reason an error is detected at power up in the non-volatile ram a warning will be issued and all settings will be returned to their default states as for a **\*RST** command.

## RS232 Remote Command Formats

Serial input to the instrument is buffered in a 256 byte input queue which is filled, under interrupt, in a manner transparent to all other instrument operations. The instrument will send XOFF when approximately 200 characters are in the queue. XON will be sent when approximately 100 free spaces become available in the queue after XOFF was sent. This queue contains raw (un-parsed) data which is taken, by the parser, as required. Commands (and queries) are executed in order and the parser will not start a new command until any previous command or query is complete. In non-addressable RS232 mode responses to commands or queries are sent immediately; there is no output queue. In addressable mode the response formatter will wait indefinitely if necessary, until the instrument is addressed to talk and the complete response message has been sent, before the parser is allowed to start the next command in the input queue.

Commands must be sent as specified in the commands list and must be terminated with the command terminator code 0AH (Line Feed, LF). Commands may be sent in groups with individual commands separated from each other by the code 3BH (;). The group must be terminated with command terminator 0AH (Line Feed, LF).

Responses from the instrument to the controller are sent as specified in the commands list. Each response is terminated by 0DH (Carriage Return, CR) followed by 0AH (Line Feed, LF).

<WHITE SPACE> is defined as character codes 00H to 20H inclusive with the exception of those which are specified as addressable RS232 control codes.

<WHITE SPACE> is ignored except in command identifiers. e.g. '\*C LS' is not equivalent to '\*CLS'.

The high bit of all characters is ignored.

The commands are case insensitive.

## GPIB Remote Command Formats

GPIB input to the instrument is buffered in a 256 byte input queue which is filled, under interrupt, in a manner transparent to all other instrument operations. The queue contains raw (un-parsed) data which is taken, by the parser, as required. Commands (and queries) are executed in order and the parser will not start a new command until any previous command or query is complete. There is no output queue which means that the response formatter will wait, indefinitely if necessary, until the instrument is addressed to talk and the complete response message has been sent, before the parser is allowed to start the next command in the input queue.

Commands are sent as <PROGRAM MESSAGES> by the controller, each message consisting of zero or more <PROGRAM MESSAGE UNIT> elements separated by <PROGRAM MESSAGE UNIT SEPARATOR> elements.

A <PROGRAM MESSAGE UNIT> is any of the commands in the remote commands list.

A <PROGRAM MESSAGE UNIT SEPARATOR> is the semi-colon character ';' (3BH).

<PROGRAM MESSAGES> are separated by <PROGRAM MESSAGE TERMINATOR> elements which may be any of the following:

NL	The new line character (0AH)
NL^END	The new line character with the END message
^END	The END message with the last character of the message

Responses from the instrument to the controller are sent as <RESPONSE MESSAGES>. A <RESPONSE MESSAGE> consists of one <RESPONSE MESSAGE UNIT> followed by a <RESPONSE MESSAGE TERMINATOR>.

A <RESPONSE MESSAGE TERMINATOR> is the new line character with the END message NL^END.

---

Each query produces a specific <RESPONSE MESSAGE> which is listed along with the command in the remote commands list.

<WHITE SPACE> is ignored except in command identifiers. e.g. '\*C LS' is not equivalent to '\*CLS'. <WHITE SPACE> is defined as character codes 00H to 20H inclusive with the exception of the NL character (0AH).

The high bit of all characters is ignored.

The commands are case insensitive.

## Command List

This section lists all commands and queries implemented in this instrument. The commands are listed in alphabetical order within the function groups.

Note that there are no dependent parameters, coupled parameters, overlapping commands, expression program data elements or compound command program headers; each command is completely executed before the next command is started. All commands are sequential and the operation complete message is generated immediately after execution in all cases.

The following nomenclature is used:

<rmt> <RESPONSE MESSAGE TERMINATOR>

<cpd> <CHARACTER PROGRAM DATA>, i.e. a short mnemonic or string such as ON or OFF.

<nrf> A number in any format. e.g. 12, 12.00, 1.2 e 1 and 120 e-1 are all accepted as the number 12. Any number, when received, is converted to the required precision consistent with the use then rounded up to obtain the value of the command.

<nr1> A number with no fractional part, i.e. an integer.

[...] Any item(s) enclosed in these brackets are optional parameters. If more than one item is enclosed then all or none of the items are required.

The commands which begin with a \* are those specified by IEEE Std. 488.2 as Common commands. All will function when used on another interface but some are of little use.

## Channel Selection

Most commands act on a particular channel of the generator. The following command is used to select the required channel. Subsequent commands will change only the specified parameter on the selected channel.

SETUPCH <nrf>            Select channel <nrf> as the destination for subsequent commands.  
                             <nrf> may take the range 1 to maximum channel number in the instrument.  
                             For a single channel instrument this is always 1.

## Frequency and Period

These commands set the frequency/period of the generator main output and are equivalent to pressing the FREQ key and editing that screen.

WAVFREQ <nrf>            Set the waveform frequency to <nrf> Hz.

WAVPER <nrf>             Set the waveform period to <nrf> sec.

CLKFREQ <nrf>            Set the arbitrary sample clock freq to <nrf> Hz.

CLKPER <nrf>             Set the arbitrary sample clock period to <nrf> sec.

WFMCLKSRC <cpd>        Set the playback clock source of the selected waveform to <INT> or <EXT>.

## Amplitude and DC Offset

AMPL <nrf>                Set the amplitude to <nrf> in the units as specified by the AMPUNIT command.

AMPUNIT <cpd>            Set the amplitude units to <VPP>, <VRMS> or <DBM>.

ZLOAD <cpd>             Set the output load, which the generator is to assume for amplitude and dc offset entries, to <50> (50Ω), <600> (600Ω) or <OPEN>.

DCOFFS <nrf>             Set the dc offset to <nrf> Volts.

---

## Waveform Selection

WAVE <cpd>	Select the output waveform as <SINE>, <SQUARE>, <TRIANG>, <DC>, <POSRMP>, <NEGRMP>, <COSINE>, <HAVSIN>, <HAVCOS>, <SINC>, <PULSE>, <PULSTRN>, <NOISE> or <SEQ>.
PULSPER <nrf>	Set the pulse period to <nrf> sec.
PULSWID <nrf>	Set the pulse width to <nrf> sec.
PULSDLY <nrf>	Set the pulse delay to <nrf> sec.
PULTRNLEN <nrf>	Set the number of pulses in the pulse–train to <nrf>.
PULTRNPER <nrf>	Set the pulse–train period to <nrf> sec.
PULTRNBASE <nrf>	Set the pulse–train base line to <nrf> Volts.
PULTRNLEV <nrf1>,<nrf2>	Set the level of pulse–train pulse number <nrf1> to <nrf2> Volts.
PULTRNWID <nrf1>,<nrf2>	Set the width of pulse–train pulse number <nrf1> to <nrf2> sec.
PULTRNDLY <nrf1>,<nrf2>	Set the delay of pulse–train pulse number <nrf1> to <nrf2> sec.
PULTRNMAKE	Makes the pulse–train and runs it – similar to the WAVE PULSTRN command.
ARB <cpd>	Select an arbitrary waveform for output. <cpd> must be the name of an existing arbitrary waveform. Backup memory is always used as the source of the arb. The arb will be copied to the channel memory if necessary.
ARBLIST?	Returns a list of all arbitrary waveforms on the memory card, each will return a name and length in the following form <cpd>,<nrf1>. The list will end with <rmt>.
CF?	Interrogates the memory card. Returns available space in MB, e.g. 21.5MB. Returns 0.0MB if either WAVES or SETUP directories are full; returns –1 if no memory card is found.
CFSIZE?	Returns the formatted capacity of the memory card in MBytes.
CFLABEL?	Returns the volume label of the memory card.

## Arbitrary Waveform Create and Delete

NOTE: Care should be take to ensure that all channels in the instrument are running in CONTINUOUS mode before using commands from this section. Failure to observe this restriction may give unexpected results.

ARBDELETE <cpd>	Delete the arbitrary waveform <cpd> from memory card.
ARBCREATE <cpd>,<nrf>	Create a new, blank arbitrary waveform with name <cpd> and length <nrf> points.
ARBDEFCSV <cpd>,<nrf>,<csv ascii data>	Define a new or existing arbitrary waveform with name <cpd> and length <nrf> and load with the data in <csv ascii data>. If the arbitrary waveform does not exist it will be created. If it does exist the length will be checked against that specified and a warning will be issued if they are different. The edit limits will be set to the extremes of the waveform, The data consists of ascii coded values, in the range –2048 to +2047, for each point. The values are separated by a comma character and the data ends with <pmt>. If less data is sent than the number of points in the waveform the old data is retained from the point where the new data ends. If more data is sent the extra is discarded.



---

**ARBDEF**  
<cpd>,<nrf>,<bin data block>

Define a new or existing arbitrary waveform with name <cpd> and length <nrf> and load with the data in <bin data block>. If the arbitrary waveform does not exist it will be created. If it does exist the length will be checked against that specified and a warning will be issued if they are different. The edit limits will be set to the extremes of the waveform. The data consists of two bytes per point with no characters between bytes or points. The point data is sent high byte first. The data block has a header which consists of the # character followed by several ascii coded numeric characters. The first of these defines the number of ascii characters to follow and these following characters define the length of the binary data in bytes. If less data is sent than the number of points in the waveform the old data is retained from the point where the new data ends. If more data is sent the extra is discarded. Due to the binary data block this command cannot be used over the RS232 interface.

## Arbitrary Waveform Editing

NOTE: Care should be taken to ensure that all channels in the instrument are running in CONTINUOUS mode before using commands from this section. Failure to observe this restriction may give unexpected results.

**ARBEDLMTS** <nrf1>,<nrf2>

Set the limits for the arbitrary waveform editing functions to start at <nrf1> and stop at <nrf2>. If both values are set to 0 the commands which use them will automatically place them at the start and end points of the relevant waveform. This automatic mode will remain in effect until the ARBEDLMTS command is issued again with non zero values. The automatic mode is always selected at power up.

**ARBDATACSV**  
<cpd>,<csv ascii data>

Load data to an existing arbitrary waveform. <cpd> must be the name of an existing arbitrary waveform. The data consists of ascii coded values, in the range -2048 to +2047, for each point. The values are separated by a comma character and the data ends with <pmt>. The data is entered into the arbitrary waveform between the points specified by the ARBEDLMTS command. If less data is sent than the number of points between the limits the old data is retained from the point where the new data ends. If more data is sent the extra is discarded.

**ARBDATA**  
<cpd>,<bin data block>

Load data to an existing arbitrary waveform. <cpd> must be the name of an existing arbitrary waveform. The data consists of two bytes per point with no characters between bytes or points. The point data is sent high byte first. The data block has a header which consists of the # character followed by several ascii coded numeric characters. The first of these defines the number of ascii characters to follow and these following characters define the length of the binary data in bytes. The data is entered into the arbitrary waveform between the points specified by the ARBEDLMTS command. If less data is sent than the number of points between the limits the old data is retained from the point where the new data ends. If more data is sent the extra is discarded. Due to the binary data block this command cannot be used over the RS232 interface.

---

ARBDATACSV? <cpd>	Returns the data from an existing arbitrary waveform. <cpd> must be the name of an existing arbitrary waveform. The data consists of ascii coded values as specified for the ARBDATACSV command. The data is sent from the arbitrary waveform between the points specified by the ARBEDLMTS command.
ARBDATA? <cpd>	Returns the data from an existing arbitrary waveform. <cpd> must be the name of an existing arbitrary waveform. The data consists of binary coded values as specified for the ARBDATA command. The data is sent from the arbitrary waveform between the points specified by the ARBEDLMTS command. Due to the binary data block this command cannot be used over the RS232 interface.
ARBRESIZE <cpd>,<nrf>	Change the size of arbitrary waveform <cpd> to <nrf>.
ARBRENAME <cpd1>,<cpd2>	Change the name of arbitrary waveform <cpd1> to <cpd2>.
ARBPOINT <cpd>,<nrf1>,<nrf2>	Set the waveform point at address <nrf1> in arbitrary waveform <cpd> to <nrf2>.
ARBLINE <cpd>,<nrf1>,<nrf2>,<nrf3>,<nrf4>	Draw a line in arbitrary waveform <cpd> from start address/data <nrf1>/<nrf2> to stop address/data <nrf3>/<nrf4>.
ARBINSSTD <cpd1>,<cpd2>,<nrf1>,<nrf2>	Insert the standard waveform <cpd2> into the arbitrary waveform <cpd1> from start address <nrf1> to stop address <nrf2>. <cpd2> must be one of <SINE>, <SQUARE>, <TRIANG>, <DC>, <POSRMP>, <NEGRMP>, <COSINE>, <HAVSIN>, <HAVCOS>, or <SINC> and <cpd1> must be an existing arbitrary waveform.
ARBINSARB <cpd1>,<cpd2>,<nrf1>,<nrf2>	Insert the arbitrary waveform <cpd2> into arbitrary waveform <cpd1>. Use that part of <cpd2> specified by the ARBEDLMTS command and insert from start address <nrf1> to stop address <nrf2>. <cpd1> and <cpd2> must both be existing arbitrary waveforms but they cannot be the same waveform.
ARBCOPY <cpd>,<nrf1>,<nrf2>,<nrf3>	Block copy in arbitrary waveform <cpd> the data from start address <nrf1> to stop address <nrf2> to destination address <nrf3>.
ARBAMPL <cpd>,<nrf1>,<nrf2>,<nrf3>	Adjust the amplitude of arbitrary waveform <cpd> from start address <nrf1> to stop address <nrf2> by the factor <nrf3>.
ARBOFFSET <cpd>,<nrf1>,<nrf2>,<nrf3>	Move the data in arbitrary waveform <cpd> from start address <nrf1> to stop address <nrf2> by the offset <nrf3>.
ARBINVERT <cpd>,<nrf1>,<nrf2>	Invert arbitrary waveform <cpd> between start address <nrf1> and stop address <nrf2>.
ARBLEN? <cpd>	Returns the length, in points, of the arbitrary waveform <cpd>. If the waveform does not exist the return value will be 0.
POSNMKRCLR <cpd>	Clear all position markers from arbitrary waveform <cpd>.
POSNMKRSET <cpd>,<nrf>	Set the position marker at address <nrf> in arbitrary waveform <cpd> to 1 (high).
POSNMKRRES <cpd>,<nrf>	Clear the position marker at address <nrf> in arbitrary waveform <cpd> to 0 (low).
POSNMKRPAT <cpd1>,<nrf1>,<nrf2>,<cpd2>	Put the pattern <cpd2> into the arbitrary waveform <cpd1> from start address <nrf1> to stop address <nrf2>. The pattern may contain up to 16 entries of '1' or '0', no other characters are allowed.

---

---

## Waveform Sequence Control

SEQWFM <nrf>,<cpd>	Set the 'waveform' parameter for sequence segment <nrf> to <cpd>. <cpd> must be the name of an existing arbitrary waveform.
SEQSTEP <nrf>,<cpd>	Set the 'step on' parameter for sequence segment <nrf> to <COUNT>, <TRGEDGE> or <TRGLEV>.
SEQCNT <nrf1>,<nrf2>	Set count for sequence segment <nrf1> to <nrf2>.
SEQSEG <nrf>,<cpd>	Set the status of sequence segment <nrf> to <ON> or <OFF>.

## Mode Commands

MODE <cpd>	Set the mode to <CONT>, <GATE>, <TRIG>, <SWEEP> or <TONE>.
BSTCNT <nrf>	Set the burst count to <nrf>.
PHASE <nrf>	Set the generator phase to <nrf> degrees. This parameter is used for setting the trigger/gate mode start/stop phase and the phase difference when synchronising channels.
TONEEND <nrf>	Delete tone frequency number <nrf> thus defining the end of the list.
TONEFREQ <nrf1>,<nrf2>,<nrf3>	Set tone frequency number <nrf1> to <nrf2> Hz. The third parameter sets the tone type; 1 will give Trig, 2 will give FSK, any other value gives Gate type.
SWPSTARTFRQ <nrf>	Set the sweep start frequency to <nrf> Hz.
SWPSTOPFRQ <nrf>	Set the sweep stop frequency to <nrf> Hz.
SWPCENTFRQ <nrf>	Set the sweep centre frequency to <nrf> Hz.
SWPSPAN <nrf>	Set the sweep frequency span to <nrf> Hz.
SWPTIME <nrf>	Set the sweep time to <nrf> sec.
SWPTYPE <cpd>	Set the sweep type to <CONT>, <TRIG> or <THLDRST> .
SWPDIRN <cpd>	Set the sweep direction to <UP>, <DOWN>, <UPDN> or <DNUP>.
SWPSYNC <cpd>	Set the sweep sync <ON> or <OFF>.
SWPSPACING <cpd>	Set the sweep spacing to <LIN> or <LOG>.
SWPMKR <nrf>	Set the sweep marker to <nrf> Hz.

## Input/Output control

OUTPUT <cpd>	Set the main output <ON>, <OFF>, <NORMAL> or <INVERT>.
SYNCOUT <cpd>	Set the sync output <ON>, <OFF>, <AUTO>, <WFMSYNC>, <POSNMKR>, <BSTDONE>, <SEQSYNC>, <TRIGGER>, <SWPSYNC> or <PHASLOC>.
TRIGOUT <cpd>	Set the trig output to <AUTO>, <WFMEND>, <POSNMKR>, <SEQSYNC> or <BSTDONE>.
TRIGIN <cpd>	Set the trig input to <INT>, <EXT>, <MAN>, <PREV>, <NEXT>, <POS> or <NEG>.
TRIGLEV <nrf>	Set the trigger threshold level to <nrf> Volts.
TRIGPER <nrf>	Set the internal trigger generator period to <nrf> sec.
FORCETRIG	Force a trigger to the selected channel. Will function with any trigger source except MANUAL specified.

---

## Modulation Commands

MOD <cpd>	Set the modulation source to <OFF>, <EXT> or <PREV>.
MODTYPE <cpd>	Set the modulation type to <AM> or <SCM>.
AMDEPTH <nrf>	Set the depth for amplitude modulation to <nrf> %.
SCMLEVEL <nrf>	Set the level for SCM to <nrf> Volts.
SUM <cpd>	Set the sum source to <OFF>, <EXT> or <PREV>.
SUMRATIO <nrf>	Set the sum ratio to <nrf>.

## Synchronising Commands

REFCLK <cpd>	Set the ref. clock bnc to <IN>, <OUT>, <MASTER> or <SLAVE>.
ABORT	Aborts an external phase synchronising operation.
PHASE <nrf>	Set the generator phase to <nrf> degrees. This parameter is used for setting the trigger/gate mode start/stop phase and the phase difference when synchronising channels.
LOCKMODE <cpd>	Set the synchronising mode to <INDEP>, <MASTER>, <FTRACK> or <SLAVE>.
LOCKSTAT <cpd>	Set the inter-channel synchronisation status to <ON> or <OFF>.

## Status Commands

*CLS	Clear status. Clears the Standard Event Status Register, Query Error Register and Execution Error Register. This indirectly clears the Status Byte Register.
*ESE <nrf>	Set the Standard Event Status Enable Register to the value of <nrf>.
*ESE?	Returns the value in the Standard Event Status Enable Register in <nr1> numeric format. The syntax of the response is <nr1><rmt>.
*ESR?	Returns the value in the Standard Event Status Register in <nr1> numeric format. The register is then cleared. The syntax of the response is <nr1><rmt>.
*IDN?	Returns the instrument identification. The exact response is determined by the instrument configuration and is of the form <NAME>, <model>, 0, <version><rmt> where <NAME> is the manufacturer's name, <MODEL> defines the type of instrument and <VERSION> is the revision level of the software installed.
*IST?	Returns <b>ist</b> local message as defined by IEEE Std. 488.2. The syntax of the response is 0<rmt>, if the local message false or 1<rmt>, if the local message is true.
*OPC	Sets the Operation Complete bit (bit 0) in the Standard Event Status Register. This will happen immediately the command is executed because of the sequential nature of all operations.
*OPC?	Query operation complete status. The syntax of the response is 1<rmt>. The response will be available immediately the command is executed because of the sequential nature of all operations.
*PRE <nrf>	Set the Parallel Poll Enable Register to the value <nrf>.
*PRE?	Returns the value in the Parallel Poll Enable Register in <nr1> numeric format. The syntax of the response is <nr1><rmt>.
*SRE <nrf>	Set the Service Request Enable Register to <nrf>.

---

*SRE?	Returns the value of the Service Request Enable Register in <nr1> numeric format. The Syntax of the response is <nr1><rmt>.
*STB?	Returns the value of the Status Byte Register in <nr1> numeric format. The syntax of the response is <nr1><rmt>.
*WAI	Wait for operation complete true. As all commands are completely executed before the next is started this command takes no additional action.
*TST?	The generator has no self-test capability and the response is always 0<rmt>.
EER?	Query and clear execution error number register. The response format is nr1<rmt>.
QER?	Query and clear query error number register. The response format is nr1<rmt>.

## Miscellaneous Commands

*LRN?	Returns the complete set up of the instrument as a hexadecimal character data block. To re-install the set up the block should be returned to the instrument exactly as it is received. The syntax of the response is LRN <Character data><rmt>. The settings in the instrument are not affected by execution of the *LRN? command.
LRN <character data>	Install data for a previous *LRN? command.
*RST	Resets the instrument parameters to their default values (see DEFAULT INSTRUMENT SETTINGS).
*RCL <cpd>	Recalls the instrument set up contained in store <cpd>. There must be a memory card containing a set-up file named <cpd> in the instrument. Recalling store named "?" sets all parameters to the default settings (see DEFAULT INSTRUMENT SETTINGS).
*SAV <cpd>	Saves the complete instrument set up to the set-up file named <cpd>. There must be a memory card with space for the setup file in the instrument.
*TRG	This command is the same as pressing the MAN/SYNC key. Its effect will depend on the context in which it is asserted. The interface command Group Execute Trigger (GET) will perform the same action as *TRG.
COPYCHAN <nrf>	Copy the parameters from the current setup chan to channel <nrf>.
HOLD <cpd>	Set hold mode <ON>, <OFF>, <ENAB> or <DISAB>. The ON or OFF forms are the same as pressing the HOLD key. The ENAB and DISAB forms are channel specific and enable or disable the action of the HOLD key or HOLD input.
FILTER <cpd>	Set the output filter to <AUTO>, <ELIP>, <BESS> or <NONE>.
SYCLKFRQ <nrf>	Set the frequency of the system clock to <nrf> Hz.
SYCLKSRC <cpd>	Set the source of the system clock to <INT> or <EXT>.
BEEPMODE <cpd>	Set beep mode to <ON>, <OFF>, <WARN>, or <ERROR>.
BEEP	Sound one beep.
LOCAL	Returns the instrument to local operation and unlocks the keyboard. Will not function if LLO is in force.
USBID?	Returns the instruments address.

Refer to Calibration section for remote calibration commands.

---

## Remote Command Summary

*CLS	Clear status.
*ESE <nrf>	Set the Standard Event Status Enable Register to the value of <nrf>.
*ESE?	Returns the value in the Standard Event Status Enable Register in <nr1> numeric format.
*ESR?	Returns the value in the Standard Event Status Register in <nr1> numeric format.
*IDN?	Returns the instrument identification.
*IST?	Returns <b>ist</b> local message as defined by IEEE Std. 488.2.
*LRN?	Returns the complete set up of the instrument as a hexadecimal character data block approximately 842 bytes long.
*OPC	Sets the Operation Complete bit (bit 0) in the Standard Event Status Register.
*OPC?	Query operation complete status.
*PRE <nrf>	Set the Parallel Poll Enable Register to the value <nrf>.
*PRE?	Returns the value in the Parallel Poll Enable Register in <nr1> numeric format.
*RCL <cpd>	Recalls the instrument set up contained in store <cpd>.
*RST	Resets the instrument parameters to their default values.
*SAV <cpd>	Saves the complete instrument set up to the set-up file named <cpd>.
*SRE <nrf>	Set the Service Request Enable Register to <nrf>.
*SRE?	Returns the value of the Service Request Enable Register in <nr1> numeric format.
*STB?	Returns the value of the Status Byte Register in <nr1> numeric format.
*TRG	This command is the same as pressing the MAN/SYNC key.
*TST?	The generator has no self-test capability and the response is always 0<rmt>.
*WAI	Wait for operation complete true. executed before the next is started
ABORT	Aborts a phase locking operation.
AMDEPTH <nrf>	Set the depth for amplitude modulation to <nrf> %.
AMPL <nrf>	Set the amplitude to <nrf> in the units as specified by the AMPUNIT command.
AMPUNIT <cpd>	Set the amplitude units to <VPP>, <VRMS> or <DBM>.
ARB <cpd>	Select an arbitrary waveform for output.
ARBAMPL <cpd>,<nrf1>,<nrf2>,<nrf3>	Adjust the amplitude of arbitrary waveform <cpd> from start address <nrf1> to stop address <nrf2> by the factor <nrf3>.
ARBCOPY <cpd>,<nrf1>,<nrf2>,<nrf3>	Block copy in arbitrary waveform <cpd> the data from start address <nrf1> to stop address <nrf2> to destination address <nrf3>.
ARBCREATE <cpd>,<nrf>	Create a new, blank arbitrary waveform with name <cpd> and length <nrf> points.
ARBDATA <cpd>,<bin data block>	Load data to an existing arbitrary waveform.
ARBDATA? <cpd>	Returns the data from an existing arbitrary waveform.

---

ARBDATACSV <cpd>,<csv ascii data>	Load data to an existing arbitrary waveform.
ARBDATACSV? <cpd>	Returns the data from an existing arbitrary waveform.
ARBDEF <cpd>,<nrf>,<bin data block>	Define a new or existing arbitrary waveform with name <cpd> and length <nrf> and load with the data in <bin data block>.
ARBDEFCSV <cpd>,<nrf>,<csv ascii data>	Define a new or existing arbitrary waveform with name <cpd> and length <nrf> and load with the data in <csv ascii data>.
ARBDELETE <cpd>	Delete the arbitrary waveform <cpd> from memory card.
ARBEDLMTS <nrf1>,<nrf2>	Set the limits for the arbitrary waveform editing functions to start at <nrf1> and stop at <nrf2>.
ARBINSARB <cpd1>,<cpd2>,<nrf1>,<nrf2>	Insert the arbitrary waveform <cpd2> into arbitrary waveform <cpd1>. Use that part of <cpd2> specified by the ARBLIMITS command and insert from start address <nrf1> to stop address <nrf2>.
ARBINSSTD <cpd1>,<cpd2>,<nrf1>,<nrf2>	Insert the standard waveform <cpd2> into the arbitrary waveform <cpd1> from start address <nrf1> to stop address <nrf2>.
ARBINVERT <cpd>,<nrf1>,<nrf2>	Invert arbitrary waveform <cpd> between start address <nrf1> and stop address <nrf2>.
ARBLEN? <cpd>	Returns the length, in points, of the arbitrary waveform <cpd>.
ARBLINE <cpd>,<nrf1>,<nrf2>,<nrf3>,<nrf4>	Draw a line in arbitrary waveform <cpd> from start address/data <nrf1>/<nrf2> to stop address/data <nrf3>/<nrf4>.
ARBLIST?	Returns a list of all arbitrary waveforms on the memory card, each will return a name and length in the following form <cpd>,<nrf1>. The list will end with <rmt>.
ARBOFFSET <cpd>,<nrf1>,<nrf2>,<nrf3>	Move the data in arbitrary waveform <cpd> from start address <nrf1> to stop address <nrf2> by the offset <nrf3>.
ARBPOINT <cpd>,<nrf1>,<nrf2>	Set the waveform point at address <nrf1> in arbitrary waveform <cpd> to <nrf2>.
ARBRENAME <cpd1>,<cpd2>	Change the name of arbitrary waveform <cpd1> to <cpd2>.
ARBRESIZE <cpd>,<nrf>	Change the size of arbitrary waveform <cpd> to <nrf>.
BEEP	Set beep mode to <ON>, <OFF>, <WARN>, or <ERROR>.
BEEPMODE <cpd>	Sound one beep.
BSTCNT <nrf>	Set the burst count to <nrf>.
CF?	Returns available Compact Flash memory capacity (-1 for no card).
CFSIZE?	Returns the formatted capacity of the memory card in MBytes.
CFLABEL?	Returns the volume label of the memory card.
CLKFREQ <nrf>	Set the arbitrary sample clock freq to <nrf> Hz.
CLKPER <nrf>	Set the arbitrary sample clock period to <nrf> sec.
COPYCHAN <nrf>	Copy the parameters from the current setup chan to channel <nrf>.
DCOFFS <nrf>	Set the dc offset to <nrf> Volts.
EER?	Query and clear execution error number register.
FILTER <cpd>	Set the output filter to <AUTO>, <ELIP>, <BESS> or <NONE>.
FORCETRIG	Force a trigger to the selected channel.
HOLD <cpd>	Set hold mode <ON>, <OFF>, <ENAB> or <DISAB>.
LOCKMODE <cpd>	Set the channel synchronisation mode to <INDEP>, <MASTER>, <FTRACK> or <SLAVE>.

---

---

LOCKSTAT <cpd>	Set the channel synchronisation status to <ON> or <OFF>.
LOCAL	Returns the instrument to local operation and unlocks the keyboard. Will not function if LLO is in force.
LRN <character data>	Install data for a previous *LRN? command.
MOD <cpd>	Set the modulation source to <OFF>, <EXT> or <PREV>.
MODE <cpd>	Set the mode to <CONT>, <GATE>, <TRIG>, <SWEEP> or <TONE>.
MODTYPE <cpd>	Set the modulation type to <AM> or <SCM>.
OUTPUT <cpd>	Set the main output <ON>, <OFF>, <NORMAL> or <INVERT>.
PHASE <nrf>	Set the slave generator phase to <nrf> degrees.
POSNMKRCLR <cpd>	Clear all position markers from arbitrary waveform <cpd>.
POSNMKRPAT <cpd1>,<nrf1>,<nrf2>,<cpd2>	Put the pattern <cpd2> into the arbitrary waveform <cpd1> from start address <nrf1> to stop address <nrf2>.
POSNMKRRES <cpd>,<nrf>	Clear the position marker at address <nrf> in arbitrary waveform <cpd> to 0 (low).
POSNMKRSET <cpd>,<nrf>	Set the position marker at address <nrf> in arbitrary waveform <cpd> to 1 (high).
PULSDLY <nrf>	Set the pulse delay to <nrf> sec.
PULSPER <nrf>	Set the pulse period to <nrf> sec.
PULSWID <nrf>	Set the pulse width to <nrf> sec.
PULTRNBASE <nrf>	Set the pulse–train base line to <nrf> Volts.
PULTRNDLY <nrf1>,<nrf2>	Set the delay of pulse–train pulse number <nrf1> to <nrf2> sec.
PULTRNLEN <nrf>	Set the number of pulses in the pulse–train to <nrf>.
PULTRNLEV <nrf1>,<nrf2>	Set the level of pulse–train pulse number <nrf1> to <nrf2> Volts.
PULTRNMAKE	Makes the pulse–train and runs it – similar to the WAVE PULSTRN command.
PULTRNPER <nrf>	Set the pulse–train period to <nrf> sec.
PULTRNWID <nrf1>,<nrf2>	Set the width of pulse–train pulse number <nrf1> to <nrf2> sec.
QER?	Query and clear query error number register.
REFCLK <cpd>	Set the ref. clock bnc to <IN>, <OUT>, <MASTER> or <SLAVE>.
SCMLEVEL <nrf>	Set the level for SCM to <nrf> Volts.
SETUPCH <nrf>	Select channel <nrf>
SEQCNT <nrf1>,<nrf2>	Set count for sequence segment <nrf1> to <nrf2>.
SEQSEG <nrf>,<cpd>	Set the status of sequence segment <nrf> to <ON> or <OFF>.
SEQSTEP <nrf>,<cpd>	Set the ‘step on’ parameter for sequence segment <nrf> to <COUNT>, <TRGEDGE> or <TRGLEV>.
SEQWFM <nrf>,<cpd>	Set the ‘waveform’ parameter for sequence segment <nrf> to <cpd>.
SUM <cpd>	Set the sum source to <OFF>, <EXT> or <PREV>.
SUMRATIO <nrf>	Set the sum ratio to <nrf>.
SWPCENTFRQ <nrf>	Set the sweep centre frequency to <nrf> Hz.
SWPDIRN <cpd>	Set the sweep direction to <UP>, <DOWN>, <DNUP> or <UPDN>.
SWPMKR <nrf>	Set the sweep marker to <nrf> Hz.
SWPSPACING <cpd>	Set the sweep spacing to <LIN> or <LOG>.
SWPSPAN <nrf>	Set the sweep frequency span to <nrf> Hz.
SWPSTARTFRQ <nrf>	Set the sweep start frequency to <nrf> Hz.

---



---

SWPSTOPFRQ <nrf>	Set the sweep stop frequency to <nrf> Hz.
SWPSYNC <cpd>	Set the sweep sync <ON> or <OFF>.
SWPTIME <nrf>	Set the sweep time to <nrf> sec.
SWPTYPE <cpd>	Set the sweep type to <CONT>, <TRIG> or <THLDRST> .
SYNCOUT <cpd>	Set the sync output <ON>, <OFF>, <AUTO>, <WFMSYNC>, <POSNMKR>, <BSTDONE>, <SEQSYNC>, <TRIGGER>, <SWPSYNC> or <PHASLOC>.
SYSCLKFRQ <nrf>	Set the frequency of the system clock to <nrf> Hz.
SYSCLKSRC <cpd>	Set the source of the system clock to <INT> or <EXT>.
TONEEND <nrf>	Delete tone frequency number <nrf> thus defining the end of the list.
TONEFREQ <nrf1>,<nrf2>,<nrf3>	Set tone frequency number <nrf1> to <nrf2> Hz. The third parameter sets the tone type; 1 will give Trig, 2 will give FSK, any other value gives Gate type.
TRIGIN <cpd>	Set the trig input to <INT>, <EXT>, <MAN>, <PREV>, <NEXT>, <POS> or <NEG>.
TRIGLEV <nrf>	Set the trigger threshold level to <nrf> Volts.
TRIGOUT <cpd>	Set the trig output to <AUTO>, <WFMENTD>, <POSNMKR>, <SEQSYNC> or <BSTDONE>.
TRIGPER <nrf>	Set the internal trigger generator period to <nrf> sec.
USBID?	Returns the instruments address.
VCAIN <cpd>	Set the vca/sum input to <VCA>, <SUM> or <OFF>.
WAVE <cpd>	Select the output waveform as <SINE>, <SQUARE>, <TRIANG>, <DC>, <POSRMP>, <NEGRMP>, <COSINE>, <HAVSIN>, <HAVCOS>, <SINC>, <PULSE>, <PULSTRN>, <NOISE> or <SEQ>.
WAVFREQ <nrf>	Set the waveform frequency to <nrf> Hz.
WAVPER <nrf>	Set the waveform period to <nrf> sec.
WMCLKSRC <cpd>	Set the playback clock source of the selected waveform to <INT> or <EXT>.
ZLOAD <cpd>	Set the output load, which the generator is to assume for amplitude and dc offset entries, to <50> (50Ω), <600> (600Ω) or <OPEN>.

---

## Maintenance

The Manufacturers or their agents overseas will provide a repair service for any unit developing a fault. Where owners wish to undertake their own maintenance work, this should only be done by skilled personnel in conjunction with the service manual which may be purchased directly from the Manufacturers or their agents overseas.

### Cleaning

If the instrument requires cleaning use a cloth that is only lightly dampened with water or a mild detergent.

**WARNING! TO AVOID ELECTRIC SHOCK, OR DAMAGE TO THE INSTRUMENT, NEVER ALLOW WATER TO GET INSIDE THE CASE. TO AVOID DAMAGE TO THE CASE NEVER CLEAN WITH SOLVENTS.**

---

## Appendix 1. Warning and Error Messages

Warning messages are given when a setting may not give the expected result, e.g. DC Offset attenuated by the output attenuator when a small amplitude is set; the setting is, however, implemented.

Error messages are given when an illegal setting is attempted; the previous setting is retained.

The last two warning/error messages can be reviewed by selecting LAST ERROR from the UTILITY screen, the latest is reported first.

Warning and error messages are reported with a number on the display; only the number is reported via the remote control interfaces.

The following is a complete list of messages as they appear on the display.

### Warning Messages

- 00 No errors or warnings have been reported
- 13 DC offset changed by amplitude
- 14 Offset + Sum + level may cause clipping
- 16 Undoing unsaved amplitude/offset edit for <waveform name>
- 23 Offset will clip the waveform
- 24 Instrument not calibrated
- 26 Wrong channel count found <count1>, require <count2>  
Issued when an attempt is made to recall a set-up file with a different channel count to that of the current instrument. The option is given to continue or cancel.
- 30 Amplitude will clip the waveform
- 42 Trigger source is fixed to external in SLAVE mode
- 59 Trigger slope is fixed to positive in SLAVE mode
- 81 The programmed mod depth cannot be set
- 83 Numeric value too large – switching to sample period

### Error Messages

- 101 Frequency out of range for the selected waveform
- 102 Sample clock frequency required exceeds 100MHz
- 103 Sample clock frequency required is less than 0.1Hz
- 104 Pulse/pulse-train period out of range for current set-up
- 105 Pulse width cannot be greater than the period
- 106 Absolute value of pulse delay must be < period
- 107 Pulse width cannot be less than 10ns
- 108 Maximum output level exceeded
- 109 Minimum output level exceeded
- 110 Minimum dc offset value exceeded
- 111 Maximum dc offset value exceeded
- 112 The value entered is out of range
- 115 There are no arb waveforms defined Use WAVEFORM CREATE
- 117 Arb name exists, names must be unique
- 118 Arb waveform length exceeds available memory
- 119 Arb waveform length cannot be less than eight points
- 121 Start address error: must be in the range  $0 \leq n \leq \text{stop addr}$
- 122 Stop address error: must be in the range  $\text{strt} \leq n \leq \text{wfm len}$
- 125 No GPIB available

- 
- 126 File has no legal set-up for this instrument
- 127 System ram error battery fault or firmware updated
- 128 Point value error: must be in the range  $-2048 \leq n \leq +2047$
- 129 Wave offset error: must be in the range  $-4096 \leq n \leq +4095$
- 131 Wave amplitude error must be in the range  $0 \leq n \leq 100$
- 132 Block dest error: must be in the range  $0 \leq n \leq \text{wfm len}$
- 133 Sequence count value exceeds the maximum of 32768
- 134 Sequence count value cannot be less than 1
- 135 Trigger generator maximum period is 200s
- 136 Trigger generator minimum period is 10us
- 137 Waveform is not available with ext clock
- 138 Burst count value exceeds the maximum of 1048575
- 139 Burst count value cannot be less than 1
- 140 Trig/Gate freq too high. Max=2.5MHz. Continuous mode set
- 141 Selected function is illegal in tone mode TONE MODE CANCELLED!
- 144 Selected combination of function and mode is illegal
- 145 Synchronised master/slave is available with continuous mode only
- 147 Current set-up requires an arb wfm which does not exist
- 148 Trig/gate mode and seq step value cause a trigger conflict
- 149 Seq step value can't mix edge and level between segments
- 150 Number of pulses in train must be between 1 and 10
- 151 Pulse train base level must be  $>-5.0V$  and  $<+5.0V$
- 152 Pulse level must be  $>-5.0V$  and  $<+5.0V$
- 153 Pulse number must be between 1 and 10
- 154 Sweep frequency values must be 1mHz to 40MHz
- 155 Sweep start freq must be less than stop freq
- 156 Sweep stop freq must be greater than start freq
- 157 Sweep time value is out of range  $0.001s < n < 999s$
- 158 Sweep marker value is out of range  $0.001Hz < n < 40MHz$
- 160 Not locked  
This error indicates that a phase locking operation has failed.
- 161 Illegal phase value
- 178 SUM ratio is not possible within level constraints
- 179 SUM and internal MOD cannot be active together
- 180 Modulation depth or SCM level is out of range
- 182 Waveform is too long for the available channel memory
- 184 SUM or Modulation conflict
- 186 Inter channel synchronisation not possible. Lock status is off.  
This error may occur for several reasons. In each case there is a conflict of the synchronisation settings. In most cases the status of the synchronisation is set to off. Any of the following conditions will cause this error;
1. More than one master channel is enabled.
  2. No master channel is enabled.
  3. The synchronised channels contain a mixture of DDS and Clock Synthesis waveforms.
  4. Frequency tracking is enabled (mode: master/freq) but the frequencies are not the same on all channels. If Clock Synthesised waveforms are synchronised the mode will be forced to frequency tracking.
-

- 
5. A synchronised channel is not set to continuous mode.
  6. An attempt is made to turn on synchronisation with a frequency set too high.
  7. An attempt is made to set the frequency too high during synchronisation. This error does not set synchronisation to off; the system simply inhibits the setting of the incorrect frequency.
- 187 EXT CLOCK independent channel illegal with int synchronisation
- 188 Maximum trigger level is +5.0V
- 189 Minimum trigger level is -5.0V
- 192 Unable to open memory card, try reinserting
- 193 Memory card is wrong format or is not formatted
- 194 Memory card is full. Cannot create WAVES or SETUP directory
- 195 Sequence segment number out of range min 1, max 1024
- 196 System clock frequency out of range
- 197 File <filename> not found load sts <waveform>
- 198 Memory card is full. Cannot create Set-up or Waveform file
- 199 Cannot format memory card. It must have 512 bytes per sector
- 220 Remove signal from Ext Ref Clock socket before editing Ref Clock

### Remote Warnings

- 72 Length is different to that in the ARBDEF(CSV) command

### Remote Errors

- 120 Waveform limit value out of range
- 126 Illegal store number requested
- 143 External clock not possible for current waveform
- 146 Remote command is illegal with external clock
- 162 Byte value outside the range 0 to 255
- 163 Specified arb name does not exist
- 164 Command illegal in sweep or tone mode
- 165 Cannot set waveform frequency or period for a sequence
- 166 Cannot set sample frequency or period for std waveforms
- 167 dBm output units assume a 50 Ohm termination
- 168 Specified units illegal for the selected waveform
- 169 Command not available for RS232
- 170 Length value error in binary block
- 171 Illegal value in arbitrary data
- 173 Illegal tone number
- 174 Illegal sequence segment number
- 175 Cannot insert arb into itself
- 176 Pattern value is illegal or pattern too long
- 177 Illegal remote calibration command.
- 185 Command not available while sweeping.
- 190 Memory card missing Waveform <filename> not loaded
- 191 Set-up file <filename> not found. Loading defaults
- OR
- Waveform <filename> not found

---

## Critical Stop Errors

These errors have no obvious recovery path and require user intervention. Some can be bypassed by a key press, some offer a choice of action. Possible hardware failures may be firmware induced and recover by cycling the power. Firmware errors all require a power cycle to recover.

Any of these errors may indicate an imminent system failure or a firmware bug.

201	CRITICAL STOP! Fault in clock circuit of channel <chan>	- possible hardware failure
202	CRITICAL STOP! Fault in calibration flash memory block	- flash write fault
203	CRITICAL STOP! Memory card removed while active	- user error
204	CRITICAL STOP! Memory card file not found: <filename>	- possible unexpected card change
205	CRITICAL STOP! Stack Overflow	- firmware error
206	CRITICAL STOP! Stack Underflow	- firmware error
207	CRITICAL STOP! Illegal instruction	- firmware error
208	CRITICAL STOP! Illegal NMI	- firmware error
209	CRITICAL STOP! Heap overflow	- firmware error

## Appendix 2. SYNC OUT Automatic Settings

The following automatic source (**src**) settings are made when **auto** mode is selected on the **SYNC OUT** screen.

MODE	WAVEFORM	Waveform Sync	Position Marker	Burst Done	Sequence Sync	Trigger	Sweep Trigger	Phase Lock
Continuous	Standard	✓						
	Arbitrary	✓						
	Sequence				✓			
Gate/Trig	All					✓		
Sweep	All						✓	
Tone	All					✓		
Ext. Phase Lock Master	Sequence				✓			
	All other							✓

---

## Appendix 3. Factory System Defaults

The factory system defaults are listed in full below. They can be recalled by pressing RECALL followed by **set defaults** or by the remote command \*RST. All channels will be receive the same setup. All channels default to the same settings.

### Main Parameters

Std. Wave: Sine  
Frequency: 10kHz  
Output: +2·0Vpp ; Output Off  
DC Offset: 0V  
Zout: HiZ

### Gate/Trigger Parameters

Source: Internal  
Period: 1ms  
Slope: Positive  
Burst Count: 1  
Phase 0deg

### Modulation Parameters

Source: Off  
Type: VCA  
Sum: Off

### Sweep Parameters

Begin Frequency: 100kHz  
End Frequency: 40MHz  
Marker Frequency: 10MHz  
Direction: Up  
Spacing: Log  
Sweep Time: 10ms  
Type: Continuous

**Filter** Auto

**Sync Out** Auto

**Sequence** (all segments set as follows)

Status: Off except seg 1.

Wfm: None selected

Step ON Count

Count: 1

**Arbitrary** All unaffected by reset or \*RST.



---

## Appendix 4. Waveform Manager Plus Arbitrary Waveform Creation and Management Software

The Thurlby Thandar Waveform Manager Plus program allows construction, editing, exchange, translation and storage of many types of waveform data. It is compatible with many popular DSOs and all TTI waveform generation products.

Waveforms may be generated by equation entry, freehand drawing, combining existing waveforms or any combinations of these methods.

Data upload and download are possible via RS232 (COM1-4), USB or GPIB subject to a compatible GPIB card being correctly installed and configured in your PC.

Files can also be uploaded/downloaded to the memory card using the USB-connected card reader/writer supplied and the card then used directly with the instrument.

Both upload and download of waveform data are possible and, where applicable, data exchange via 3.5 in floppy disks in the Tektronix \*.ISF format is available.

Text data may be read from the Windows clipboard and used to create a waveform. The text data format is very free and will allow most lists of numbers, with or without intervening text, to be read as waveform data points. Waveform data may also be pasted to the clipboard for insertion into other programs.

Waveforms are displayed in fully scaleable windows and may be manipulated graphically. Any number of waveforms in any of the supported types may be displayed simultaneously.

On-line help is available in three ways.

1. The help menu contains a contents option from which you can go to any section of the on-line help file or browse particular areas or the whole file. It is also possible to use the Index and Find operations of the Windows help system to search for items which are not listed directly in the contents section.
2. Some dialog boxes have a Help button which, when clicked, will open the on-line help file at the section containing the description of that dialog box.
3. From most windows/dialogues the F1 key will open the help file at the relevant section.

Waveform Manager allows you to keep waveforms for different projects separate from each other on your hard drive. A project may be placed anywhere, in any directory (folder) and all waveform files for that project will be stored in a structure below that directory. A project is identified by a user defined name. Each project maintains its own library of expressions.

# Block Diagrams

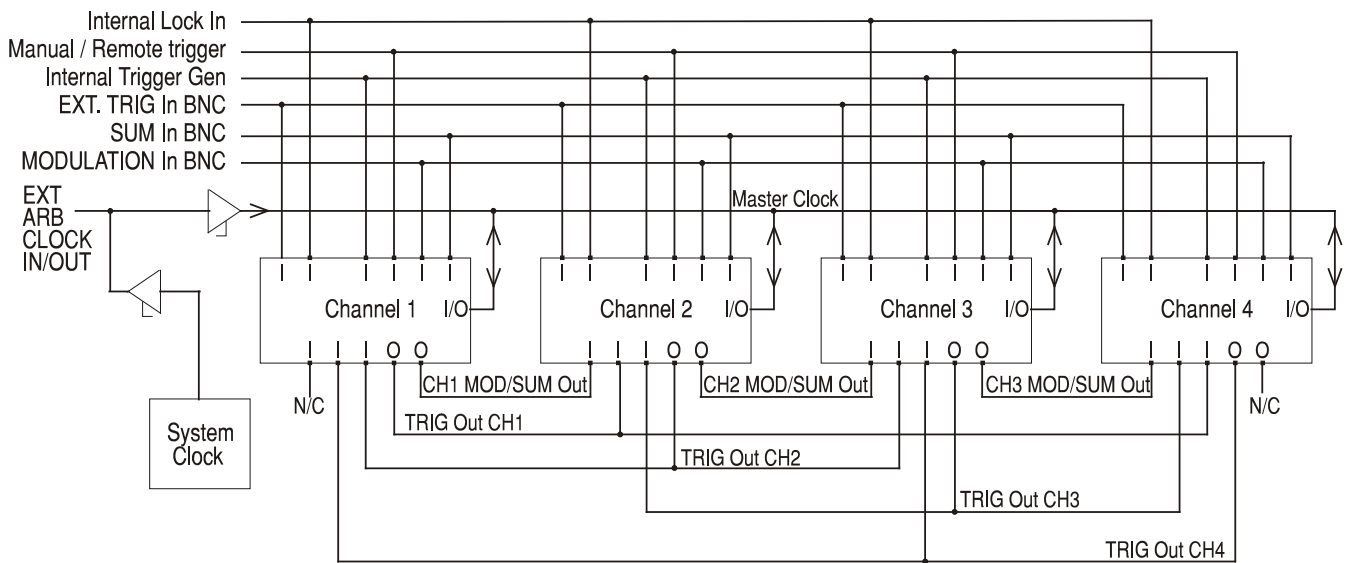

INTER-CHANNEL BLOCK DIAGRAM

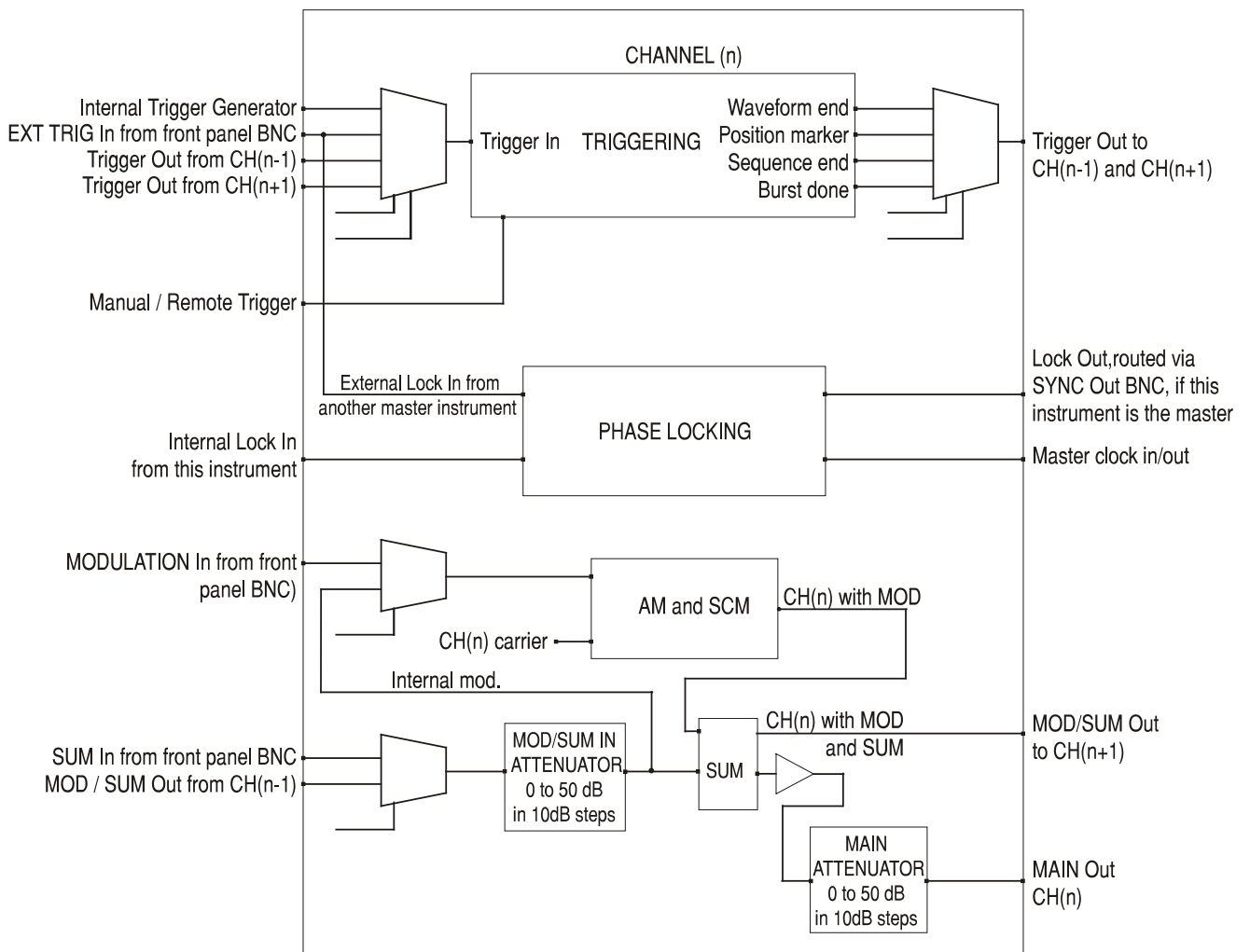

SINGLE CHANNEL BLOCK DIAGRAM

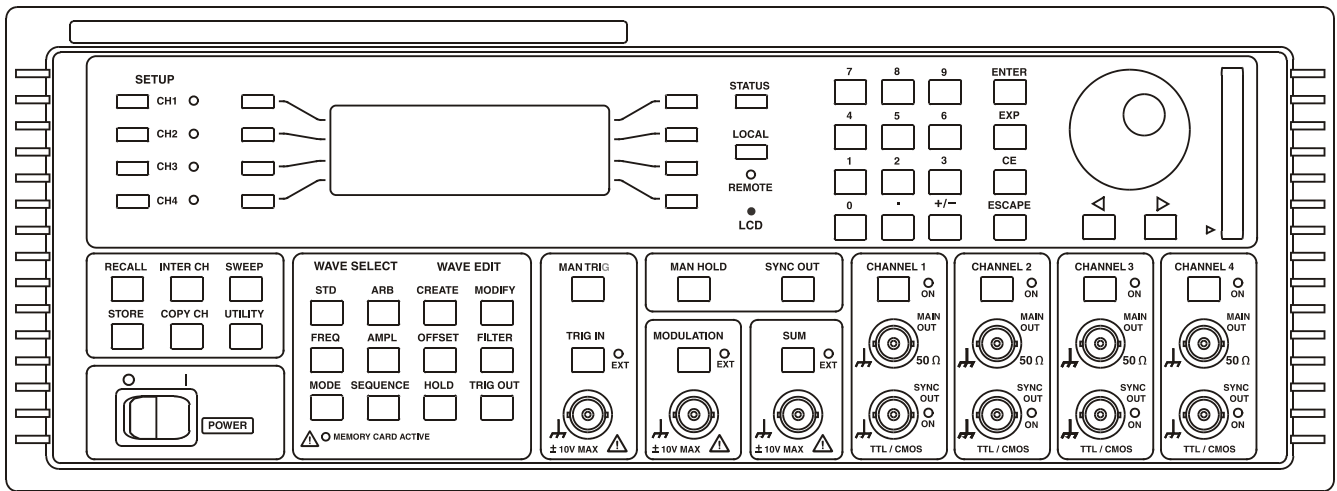

4-CHANNEL

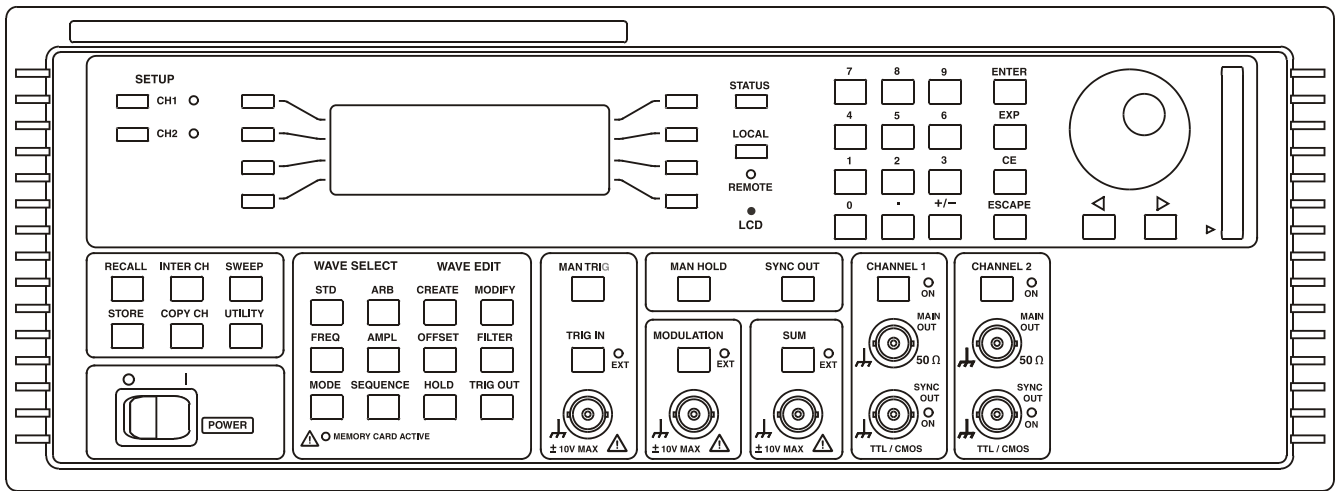

2-CHANNEL

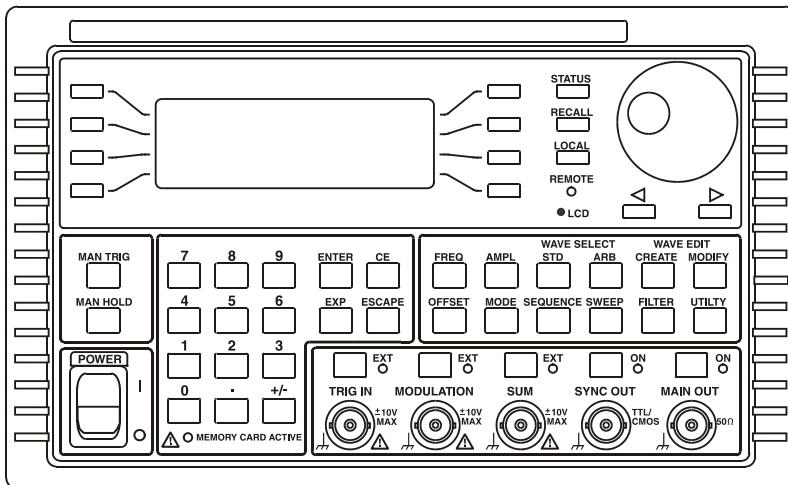

SINGLE CHANNEL



**Thurlby Thandar Instruments Ltd.**

Glebe Road • Huntingdon • Cambridgeshire • PE29 7DR • England (United Kingdom)

Telephone: +44 (0)1480 412451 • Fax: +44 (0)1480 450409

International web site: [www.aimtti.com](http://www.aimtti.com) • UK web site: [www.aimtti.co.uk](http://www.aimtti.co.uk)

Email: [info@aimtti.com](mailto:info@aimtti.com)

